

3.	The Cutter Suction Dredger	2
3.1.	General description.....	3
3.1.1.	Areas of application.....	4
3.1.2.	History	5
3.1.3.	Working method.....	6
3.2.	The design.....	8
3.2.1.	The production capacity	9
3.2.2.	The dredging depth.....	9
3.2.2.1.	The maximum dredging depth.....	9
3.2.2.2.	The minimum dredging depth	10
3.2.3.	The width of the cut.....	12
3.2.4.	The type of soil.....	14
3.2.5.	The transport distance.....	14
3.2.6.	Access to the dredging site	15
3.3.	The dredging equipment	15
3.3.1.	The cutter head	16
3.3.1.1.	The dimensions of the cutter head	16
3.3.1.2.	The cutting power.....	16
3.3.1.3.	The cutter speed.....	17
3.3.2.	The reaction forces on the cutter	18
3.3.2.1.	The horizontal and vertical cutting force.....	18
3.3.2.2.	The axial force	20
3.3.2.3.	The ladder weight	21
3.3.3.	The side-winch power and speed.....	21
3.3.4.	The ladder winch speed and power	24
3.3.5.	The dredge pumps	24
3.3.6.	The jet pump.....	25
3.4.	The drives	25
3.4.1.	The cutter head drive	25
3.4.2.	The side winch drives.....	27
3.4.3.	The ladder drive.....	27
3.4.4.	The sand pump drives.....	27
3.5.	Spudsystems.....	28
3.5.1.	The spud carriage system	28
3.5.2.	The fixed spud system	30
3.5.3.	The spud door system.....	32
3.5.4.	The walking spud system	32
3.5.5.	The rotor spud system	33
3.5.6.	The Christmas tree.....	34
3.6.	The general layout	35
3.7.	Technical construction	
	Fout! Bladwijzer niet gedefinieerd.	
3.7.1.	The Hull.....	40
3.7.2.	The cutter head ladder	41
3.7.3.	The cutter head	43
3.7.4.	Tooth and cutting edge systems	46
3.7.5.	The side wires.....	50
3.7.6.	The anchor booms	51
3.7.7.	The spuds.....	52
3.7.8.	The spud lifting system	52
3.7.9.	Pumps and pipelines.....	53
3.7.9.1.	The suction pipeline	53
3.7.9.2.	The pumps	54

3.7.10.	The winches	55
3.7.10.1.	The ladder winch	55
3.7.10.2.	The side winces	55
3.7.10.3.	Other winces	56
3.7.11.	Hoisting equipment	56
3.7.12.	Auxiliary equipment	56
3.8.	The dredging process	57
3.8.1.	The spillage	57
3.8.2.	The production in breach-forming soils	59
3.8.3.	The production by non-breach forming soils	61
3.8.4.	Specific energy	63
3.8.5.	The cutting production	65
3.8.6.	The spillage	67
3.9.	Enclosures	68
3.9.1.	The relation between swing speed and side winch speed	68
3.9.2.	The side winch force and power	69
3.9.3.	The shape and cutting geometry of cutter heads	70
3.9.4.	Cutting by teeth or chisels	74
3.9.5.	Conditions for cutting clearance	75
3.9.5.1.	The effect of warping on the clearance angles	77
3.10.	References	79

3. The Cutter Suction Dredger



Figure 3. 1 The "Mashhour", at present the biggest cutter suction dredger in the world,

3.1. General Considerations

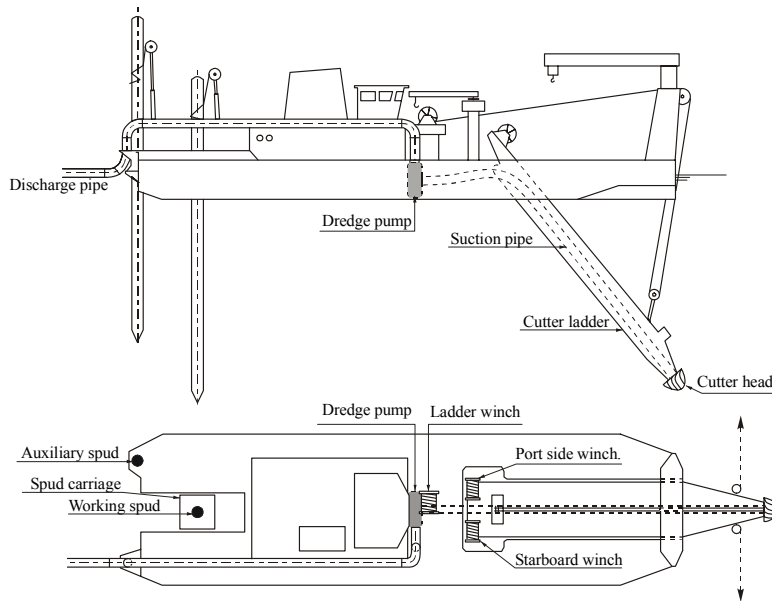

Figure 3.2 Lay-out snijkopzuiger.

The cutter suction dredger is a stationary dredger equipped with a cutter device (cutter head) which excavate the soil before it is sucked up by the flow of the dredge pump(s).

During operation the dredger moves around a spud pole by pulling and slacking on the two fore sideline wires. This type of dredger is capable to dredge all kind of material and is accurate due to their movement around the spud pole. The stationary cutter suction dredger is to distinguished easily from the plain suction dredger by its spud poles, which the last don't have.

The spoil is mostly hydraulically transported via pipeline, but some dredgers do have barge-loading facilities as well. Cutter power ranges from 50 kW up to 5000 kW, depending on the type of soil to be cut.

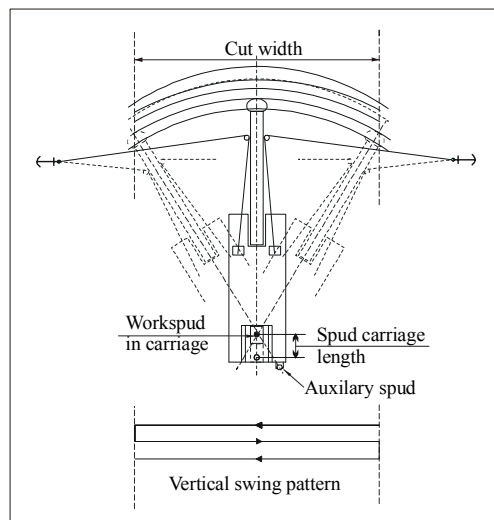

Figure 3.3 Swing pattern

The ladder, the construction upon which the cutter head, cutter drive and the suction pipe are mounted, is suspended by the pontoon and the ladder gantry wire.

Seagoing cutter suction dredgers have their own propulsion that is used only during mobilization. The propulsion is situated either on the cutter head side or on the spud poles side.

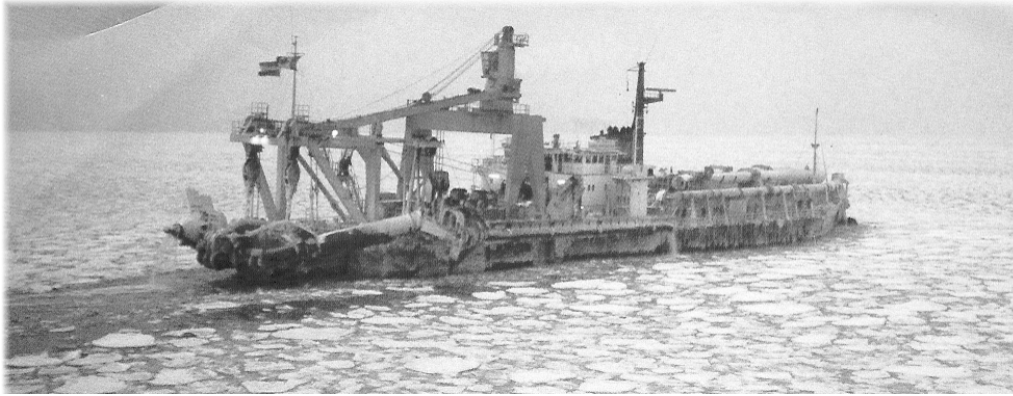

Figure 3. 4 Seagoing CSD Aquarius sailing in the Beaufort Sea

3.1.1. Areas of application

Cutter suction dredgers are largely used in the dredging of harbours and fairways as well as for land reclamation projects. In such cases the distance between the dredging and disposal areas is usually smaller than the distances covered by trailing suction hopper dredgers. The cutter suction dredger also has the advantage when an accurate profile has to be dredged. The cutter suction dredger can tackle almost all types of soil, although of course this depends on the installed cutting power. Cutter suction dredgers are built in a wide range of types and sizes, the cutting head power ranges between 20 kW for the smallest to around 4,000 kW for the largest. The dredging depth is usually limited; the biggest suction dredger can reach depths between 25 and 30 m. The minimum dredging depth is usually determined by the draught of the pontoon.

In the late seventies and early eighties of the previous century two offshore cutter suction dredgers have been build for applications offshore. The All Wassl (Figure 3.5) build by Mishubitsi, Japan for Gulf Cobla Ltd. Has dredged the approach channel to the harbour Jebel Ali in Dubai, Unit Arab Emirates.



Figure 3. 5 All Wassl Bay

After 2 years working the dredger is sold and scrapped. The Simon Stevin (Figure 3.6) build for Volker Stevin Dredging has even never worked. Boths dredgers appeared too specialised to be economical.

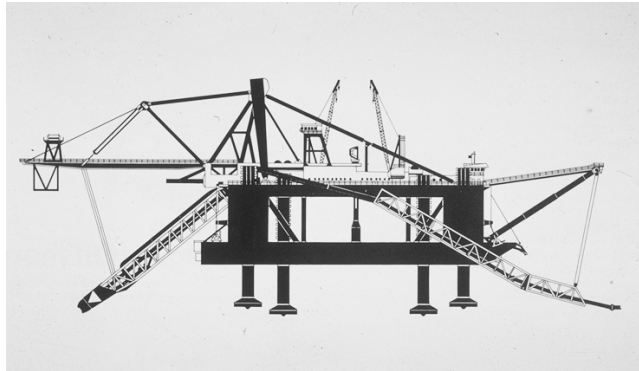

Figure 3. 6 Simon Stevin

As said the cutter suction dredger is a stationary dredger with at least two side anchors that are necessary for the dredging process. Because of these anchors they may obstruct shipping movements. Self propelled cutter suction dredgers uses their propulsion system no only during mobilisation but also during shifting from one place to the other or when the dredging area has to be left, “breaking up” when bad weather is expected.

The small to medium sized cutter suction dredgers can be supplied in a demountable form. This makes them suitable for transport by road to inland sites that are not accessible by water, for example to lay a sand foundation for a road or to dredge sand and gravel for the building industry.

When working under offshore condition with waves or swell cutter suction dredgers clearly have more limitations than trailing suction hopper dredgers even if equipped with swell compensators

3.1.2. History

The cradle of the cutter suction dredgers stood in the United States. In 1884 a cutter suction dredger was used in the port of Oakland, California. This dredger had a cylindrical cutter head and was used to dredge layers of sandstone. It had a pipeline of 500 mm diameter and a pump with an impeller of 1.8 m! The disadvantage of this design was that the suction mouth was frequently blocked. At the end of the 19th century and beginning of the 20th century there was a major development in suction dredgers

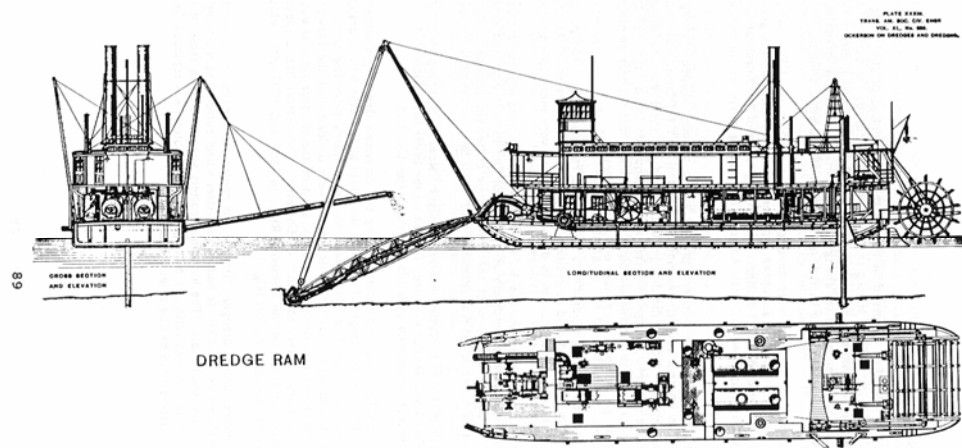

Figure 3.7 Layout of the cutter suction dredger "RAM"

For example, in the fall of 1893 the cutter suction dredger "RAM" was built by the Bucyrus Steam Shovel and dredged company for use on the lower Mississippi river. This dredger was already equipped with an rotating cutter head. (Figure 3.7).

The cutter suction dredger became the workhorse of the dredging industry in America, as did the bucket dredger in Europe at that time.

3.1.3. Working method

After the ladder of the cutter suction dredger has been lowered under water, the dredge pump(s) started and the cutter head set in motion. The ladder is then moved down until it touches the bottom, or until it reaches the maximum depth. The movement of the dredger round the spud pole is initiated by slacking the starboard anchor cable and pulling in the port side anchor cable or reverse. These anchor cables are connected via sheaves close to the cutter head to winches (dredging side winches) on deck. The pulling winch is called the hauling winch. The paying out winch ensures the correct tension in both cables, this being particularly important when dredging in hard rock.

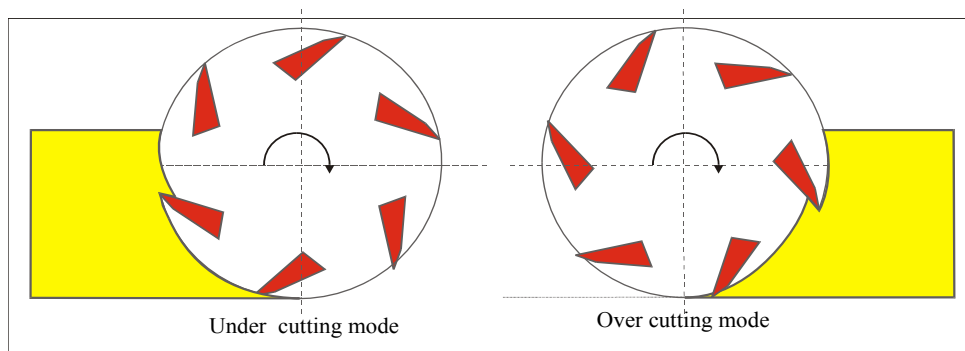

Figure 3. 8 Different cutting modes

In addition to the type of soil, the required side winch force also depends on:

- Whether the rotation of the cutter head is in the same direction as or the opposite direction to that of the swing movement. In the first case the reaction force of the cutter head on the soil will pull the dredger with it, as a result of which the side winch forces are smaller than when rotation is in the opposite direction
It is also necessary to ensure the correct pre-tensioning of the cables when the cutter head rotates in the same direction as swing. If the cutter head forces propel the cutter head more quickly than the hauling winch does there is a very real danger that the cable of the hauling winch will be picked up and cut through by the cutter head.
- The position of the anchors has a big influence on the force needed to swing the dredger. The closer the path of the cutter head is to the direction of the side cable, the smaller the required force.
- Naturally the side winch force is also affected by external influences such as wind, current and waves.

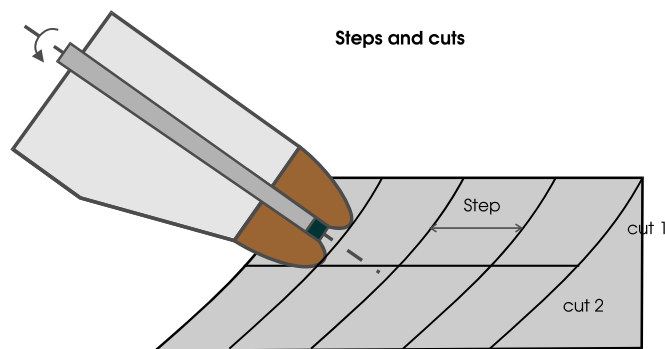

Figure 3. 9 Steps and cuts

Of course, the thickness of the layer that can be removed by one swing (cut thickness Figure 3.9) depends on both the diameter of the cutter head and the type of soil. When the required dredging depth has not been reached at the end of a swing, the ladder is set more deeply and the ship will move in the opposite direction.

As previously mentioned, the cutter suction dredger describes an arc round a fixed point, the spud pole or working pole. In many cutter suction dredgers this pole is mounted on a movable carriage, the spud carriage. A second pole, the auxiliary spud, is set out of the centreline, usually on the starboard side of the stern of the pontoon.

The spud carriage can be moved over a distance of 4 – 6 m by means of a hydraulic cylinder. Because the spud is standing on the bottom, pressing the spud carriage towards the stern can move the cutter suction dredger forward. The size of the cutter head and the hardness of the soil determine the size of this 'step'. During each step one or more layers of the face are cut away by lowering the ladder one cutting thickness at the end of the swing.

With each step the cutter head describes the arc of a concentric circle round the spud, the radius of which increases with the step length.

(Figure 3.10)

- a) = step length
b) = length of carriage

If the spud carriage cylinder has reached the end of its path the spuds must be moved. Before stepping, the cutter moves to the centre line of the cut.

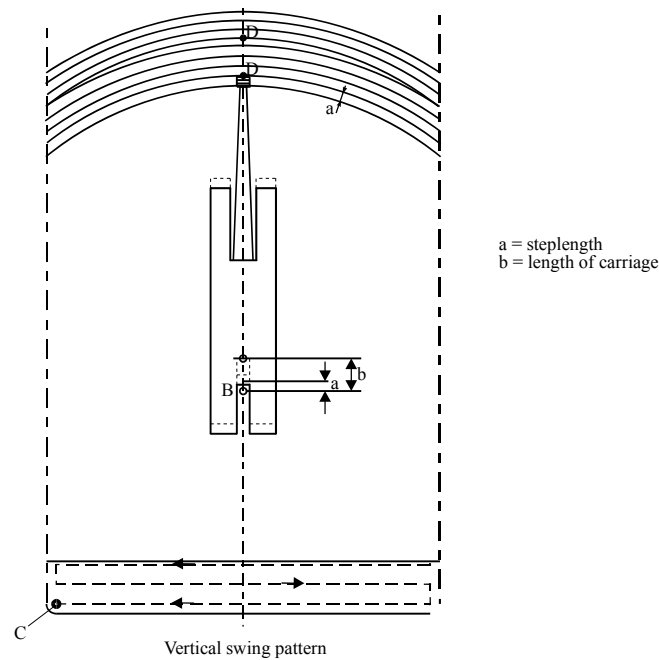

Figure 3. 10 Vertical swing pattern

The auxiliary spud is then placed on the bottom, the working spud is lifted and the spud carriage is moved forward. After this the work spud is again lowered and the auxiliary spud is lifted. The dredger can then resume working. The first cut made after stepping is not an arc of a concentric circle!

3.2. The design

When designing cutter suction dredgers, the following basic design criteria are important:

- Production capacity
- Dredging depth
- Working conditions which affect the size of the dredger
- Type of soil
- Transport distance(s)
- Access to the side

As mentioned earlier, the cutter suction dredger can be used in all types of soil, from soft clay to hard rock. The soil to be dredged has a great influence on the design and construction. Considerable forces are generated when working in rock. They are generated by the cutter head and returned to the ground partly via the ladder and side winches and partly via the pontoon and the spud pole. The design of cutter suction dredgers is also determined by the required amount of installed cutting power.

3.2.1. The production capacity

As in the case of other types of dredger, the production capacity is determined by the market demand with regard to the projects for which the dredger can be used. Because many cutter suction dredgers must dredge various types of soil during their lifetime, design parameters are set with regard to the types of soil the dredger must be able to dredge. A dredger designed to dredge rock will also be able to dredge sand, but a 'sand' cutter suction dredger will not be able to dredge rock. On the other hand a 'sand' cutter suction dredger will be able to dredge sand more cheaply than a 'rock' cutter suction dredger. In other words the design production capacity of a cutter suction dredger is related to the hardness of the material that it must be able to dredge. For example, 100 m³/hr in a rock of 10 MPa.

It is important that the production capacity is defined m³ per week, hour or second. The smaller the unit of time chosen, the greater the production capacity. (As a result of averaging the long term production capacity is less.)

When the requirement with regard to the production capacity in the design-soil is known, this can be translated into a production to be cut by the cutter head. This so called cutter production is considerably higher than the dredged production because not all the material that has been cut enters the suction mouth. Often 20 – 30 % remains behind as spillage. This must be taken into account when determining the production to be cut.

The maximum cutter production is also higher for reasons such those described above as a result of the unit of time. With a cutter suction dredger this appears primarily in the mode of work employed. Production is usually highest in the middle of a cut. In the corners of the cut where manoeuvres are often carried out with the ladder or spud carriage, the production is low or zero. This results in the fact that the cutter production when expressed in m³/s is 20 – 30% higher than the cutter production in m³/hr.

In order to maintain a high degree of usability cutter suction dredgers designed for rock dredging should be equally as good in other types of soil. This implies that although the cutting equipment is designed for rock dredging with regard to the other parts of the dredging equipment, the other types of soil must not be forgotten.

3.2.2. The dredging depth

When designing cutter suction dredgers both the maximum and the minimum dredging depths must be taken into consideration, since these both influence the usability of the dredger. Often the need for a greater dredging depth leads to a pontoon with deeper draught and thus to a reduction in the minimum dredging depth. So on one hand the usability of the dredger increases with increasing dredging depth, while on the other hand it decreases as a result of the related smaller minimum dredging depth. Here too the market demand plays a role in the best choice.

The maximum dredging depth

The maximum dredging depth is an important design parameter. Because in a cutter suction dredger the pontoon and the spud pole transfer part of the interplay of forces to the soil, the magnitudes of the moments that occur are proportional to the dredging depth. Thus with increasing dredging depth, not only is the dredger larger and broader (for stability), it must also have a heavier construction. Moreover the dredging depth has a great influence on the design of the ladder construction and thus on the pontoon. After all it must be possible to raise the ladder above water for inspection.



Figure 3. 11 Different cutter dredgers with ladder above waterlevel

From the point of view of production, the suction depth determines whether an underwater pump is needed to obtain the required production capacity. It is obvious that mounting an underwater pump will increase the weight of the ladder.

If no underwater pump is considered, the diameter of the suction pipe and the head of the pump must be increased and the concentration of the mixture reduced in order to avoid creating a vacuum. This may lead to the pumping of low concentrations and thus much water, which is uneconomic.

With the aid of the vacuum formula (see also lecture notes 'Dredging processes'), from a given limiting vacuum and the maximum concentration to be dredged it is possible to determine whether or not an underwater pump is necessary, and if so how far under water it must be placed. Whether or not an underwater pump is fitted is, of course, also a question of economics, since cost of the fitting of an underwater pump is considerable.

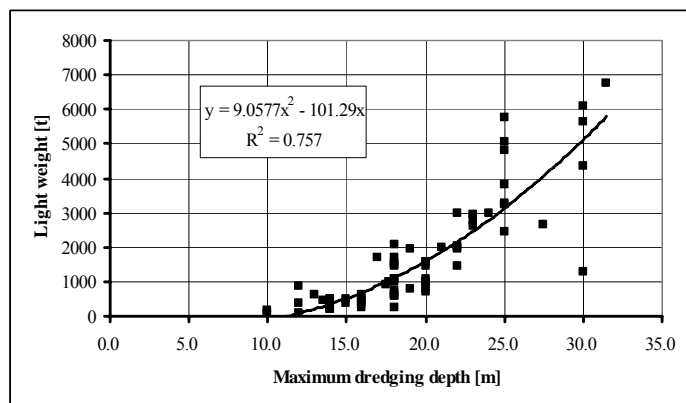

Figure 3. 12

The minimum dredging depth

The minimum dredging depth makes demands with regard to the draught of the pontoon, the position of the cooling water inlet and the shape and construction of the cutter ladder. It will be clear that even when dredging at minimum depths the pontoon must have sufficient bottom clearance. For heavy duty cutter suction dredgers this leads to deep draughts or wide vessels (Figure 3.13). The minimum dredging depth must be at least 1 m deeper than the maximum draught of the vessel. The design of the cooling water inlet must be adapted to prevent the intake of material from the bottom

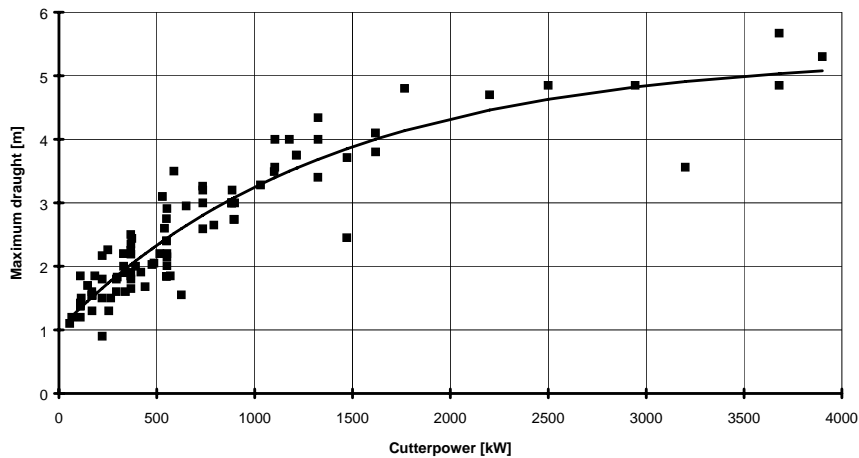

Figure 3.13

When dredging at depths, which are shallow in comparison to the draught of the vessel, the shape of the ladder must also be adapted to avoid dragging of the ladder. To prevent dragging the angle γ between the underside of the ladder and the horizontal must be at least 5° (Figure 3.14).

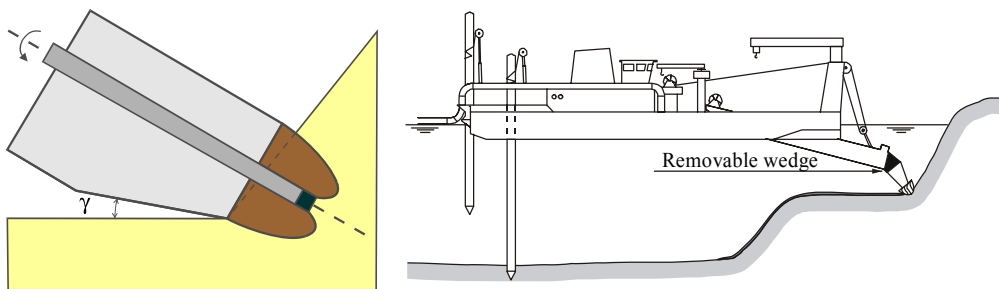

Figure 3.14

In order to obtain a better rate of filling when dredging free running material is desirable that the axis of the cutter head shaft should make a steeper angle with the horizontal than the ladder. The filling of the cutter is determined by the sum of the angles of the slope gradient and the ladder ($\alpha + \beta$) (Figure 3.15).

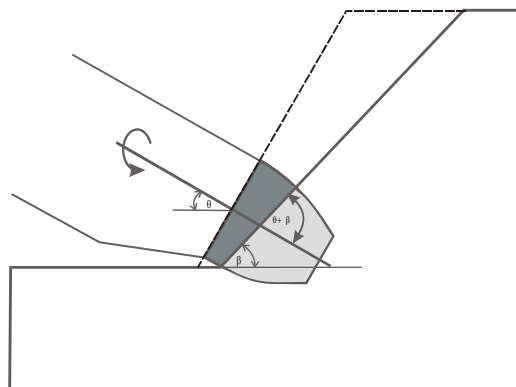

Figure 3.15

3.2.3. The width of the cut

The usefulness of a cutter suction dredger is also determined by the minimum width of cut that the equipment can dredge, and to a lesser degree on the maximum width of the cut.

‘Minimum width’ of cut is taken to mean the width that the dredger needs to dredge a channel for itself in an area where the surface of the ground is higher than the water level; a problem that occurs is during dredging the onshore end of pipeline trenches.

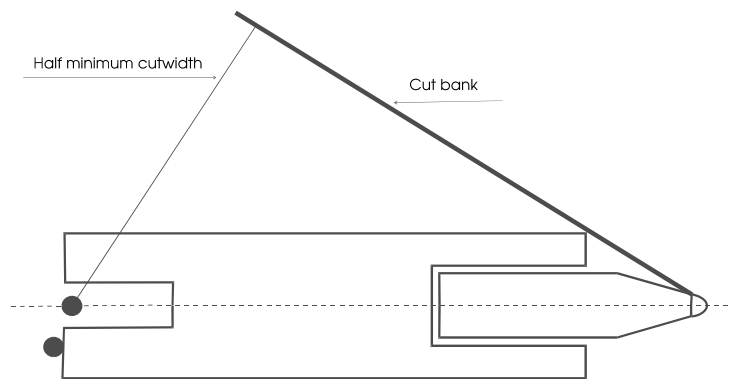

Figure 3. 16 Minimum cut width

The minimum width of the cut is determined by the line that meets the contour surface of the cutter head at the front of the pontoon (Figure 3.16) or at the outer side of the side winch sheaves. To reduce the minimum cutting width each side of the front of the pontoon is often chamfered as shown in Figure 3.17 and 3.19. Figure 3.18 also shows that the further the cutter head projects in front of the pontoon, the smaller is the minimum cutting width. Such a solution is particularly common in American and Japanese dredgers.

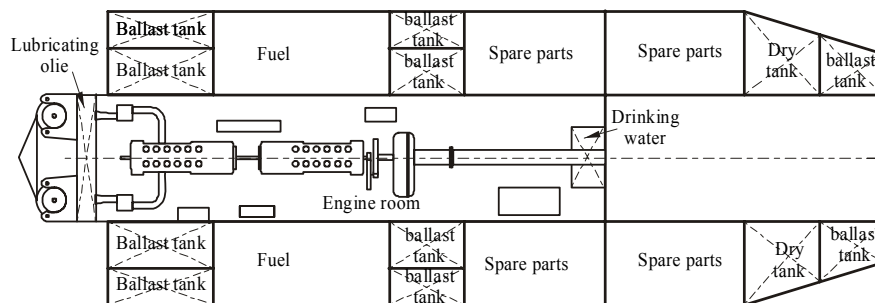

Figure 3. 17 Chamfered pontoon



Figure 3.18



Figure 3.19

The distance between the spud and the cutter head determines the maximum cutting width. To ensure the efficiency of the side winches the maximum swing angle is restricted to 45° ; so that the maximum width $B = 2L \cdot \sin(45^\circ) + D_{\text{cutter}}$, in which L is the distance between the spud and the cutter head. The length L depends on the depth of the water and the position of the spud pole.

From the point of view of production a broad cutting width is desirable, since per m^3 dredged the downtime for stepping, anchoring and other manoeuvres is shorter. However long cutter suction dredgers have a big minimum cutting width, so the advantages must be weighed against the disadvantages. The maximum cutwidth depends on the maximum side winch force too. This will be explained in chapter 3.2.2.3

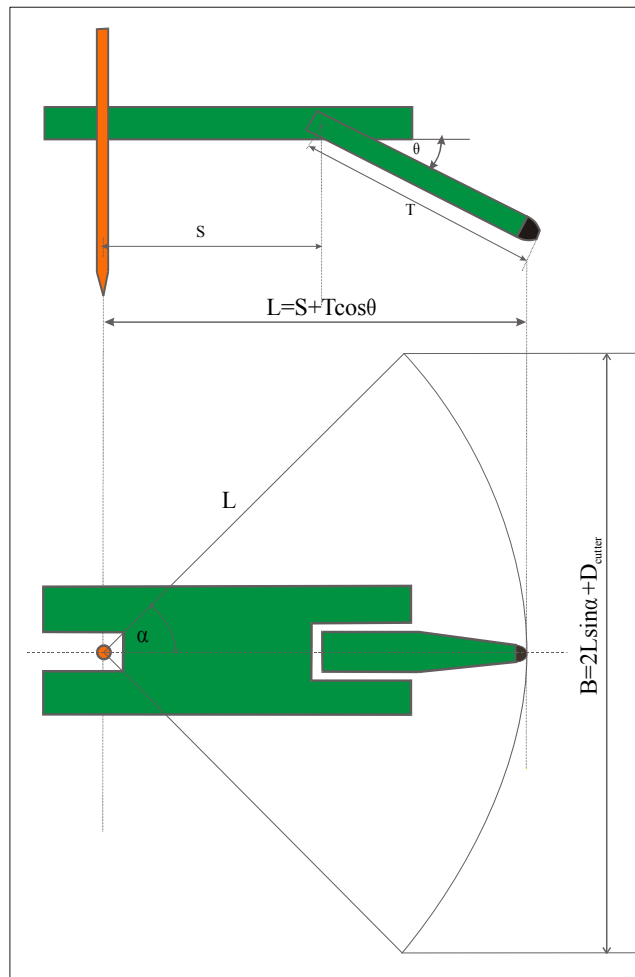

Figure 3.20 Cut width

3.2.4. The type of soil

The type of soil to be dredged has a strong influence on the installed cutter head and side winch power, the strength of the ladder, pontoon and spuds. To some degree the type of soil also influences the choice of suction pipe and discharge pipeline diameters. With the same cutting power a cutter suction dredger dredging rock will have a lower production rate than when dredging sand. In view of this, a rock-cutting cutter suction dredger should have pipelines of smaller diameter, because it becomes more economical to pump solids with higher concentrations. With the same production rate it is possible to increase the concentration by reducing the pump flow. Because a minimum velocity is required to transport solids this can only be achieved by reducing the diameter of the pipelines. It must be noted that reduction of the pump flow may lead to a higher percentage of spillage resulting caused by a bad mixture forming-process in the cutter head. (See Dredging Processes, Spill.)

3.2.5. The transport distance

The transport distance makes demands in relation to the installed sand pump power and the need to load barges. The requirement to load barges is determined by the question of whether the required transport distance is too great to be economically bridged by using a hydraulic pipeline. It is also possible that the use of a hydraulic pipeline is impossible from the point of view of hindrance to navigation. Cutter suction dredgers are seldom equipped to load barges only. Figure 3.21 shows the CD Marco Polo barge loading in the busy waters of Singapore. If the cutter suction dredger is equipped with an underwater pump, the pump power can be such that during the loading of barges this pump is used only. The pipeline system and valves should be designed to fulfil this requirement.



Figure 3. 21 CD Marco Polo

It is also possible to choose an underwater pump with a higher power than is needed for barge loading. The surplus capacity can then be used during discharging.

The grain size and the discharge length of the pipeline determine the required pump pressure, while this determines the number of dredgepumps required.

The maximum allowable pump pressure that a dredger can supply depends on the quality of the shaft sealing of the last pump. Often values exceeding 25 - 30- bar are not permitted.

3.2.6. Access to the dredging site

Dredging sites are not always easy accessible via water. The access can be very shallow and have to be dredged deeper before the actual dredging can start. If there is no access via water at all, the dredger have to be mobilised to the site by road. This is only possible with small demountable dredgers.

In case of long contracts, such as for the tin and gold mining the dredgers can be constructed on the dredging site. Both cases do influence the design of the dredger. Figure 3.17 shows a general plan of a demountable dredger consisting of one main middle pontoon and two side pontoons.



Figure 3. 22

Another point in relation with access to the site is the possible restriction height of the dredger.

High ladder and spud gantries can be a problem by passing bridges or electrical cables. Compare the different designs of the dredgers in Figure 3.22 and Figure 3.23

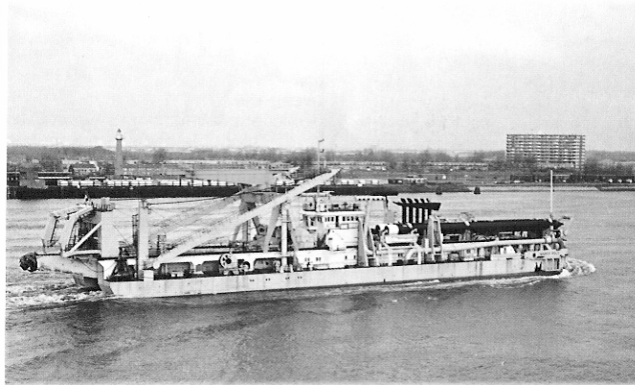

Figure 3. 23

3.3. The dredging equipment

For the design of the dredging equipment the following dredging parts will be considered:

- The cutter head
- The bow side-winch power
- The axial cutting force
- The vertical cutting force
- The ladder winch power
- The drives
- The dredge pump
- The sand pump drive
- The water pump
- The spud system

3.3.1. The cutter head

The cutter head is the most important part for this type of dredger, because it determines the production in many cases that shall be excavated and transported. For the production is besides the required cutting power also the cutter head speed and the dimensions important. The cutting power to be able to cut the soil. The cutter head speed is important for the mixture forming process and the dimensions should be in relation to the cutting power and the production.

Further it is important to know the reaction of the cutting process working on the cutter head for determining the side winch forces, speed and power; the ladder weight, ladder inch forces, ect.

The dimensions of the cutter head

The production capacity is affected not only by the cutting power, the side winch power and the velocity, but may also depend on the diameter of the cutter head. This is the case when the side winch force, the side winch velocity and the cutting torque are not limiting factors. Production can only be increased by increasing the cut thickness and step size, thus increasing the cutter head dimension. The dimensions should be in relation with the theory described in chapter 3.3.2

The cutting power

The required cutting power can be determined either from the cutting theories (Lecture notes Wb 3413) or from the required specific energy that is needed to cut the design-soil. The specific cutting energy SPE is defined as the work that is needed to cut m^3 of soil, that is the power P that is needed to cut a production Q_{cutter} of m^3/s , thus

$$SPE = \frac{P_{\text{Cutter}}}{Q_{\text{Cutter}}} \quad [N/m^2]$$

The cutting power is therefore:

$$P_{\text{Cutter}} = Q_{\text{Cutter}} * SPE \quad [W]$$

When cutting soil the cutting force is seldom constant due to the inconstancy of the soil.

Therefore the terms 'average cutting force' and 'peak forces' are used. The peak forces for rock may well be a factor 2 higher than the average forces (Verhoef, 1997)

The following may be used as rules of thumb:

$\frac{F_{\text{peak}}}{F_{\text{mean}}} = 1.5 - 2$	for rock; depending whether the cutting process is ductile or brittle.
$\frac{F_{\text{peak}}}{F_{\text{mean}}} = 1.25 - 1.5$	for sand
$\frac{F_{\text{peak}}}{F_{\text{mean}}} = 1.1 - 1.5$	for clay, depending whether the cutting process is flow, tear or shear type.

The theoretical cutting power must also be multiplied by these factors. The revolution velocity of the cutter head is also dependent on the type of soil.

Note: This factor should be included in the work coefficient as mentioned in chapter¹

¹ Reference to be made

The cutter speed

Specific energy decreases as the rock size increases. In rock a nominal cutter head speed of 30 revolutions per minute is often used. Lower nominal revolution rates leads to bigger rock pieces and so to lower specific energy but also to higher torques and cutting forces. Higher cutting torques and forces can also be achieved by reducing the diameter of the cutter head. Except that the rock size does not increase in this case the maximum thickness of the cut decreases and thus the maximum production will reduce.

Both cutter head speed and pump capacity have big influence on the spillage of the cutter. Spillage is the material that is cut but not sucked up by the dredged pump.

Den Burger (1999) showed from his research on laboratory scale that the optimal cutter head speed in rock depends a little with the pump capacity (Figure 3. 24)

Translation of the optimum results for the different mixture velocities or pump capacities to prototype values leads to Figure 3. 25 when using the scale laws as describe by den Burger. It should be noticed that for a cutter head with a diameter of 3 m the pump capacity should be more than 5 m³/s (mixture speed 5m/s) to get a relative production of a little more than 70% (30% spillage). Reducing the cutter head diameter with a half a meter results in more acceptable practical values for the pump capacity with a cutter head speed of a little less than 40 rpm. Higher speed will give in rock smaller particles and therefore less spillage.

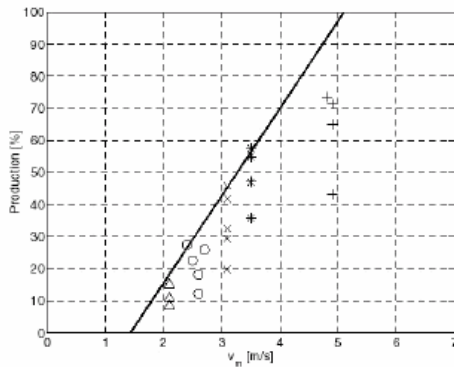

Fig. 4: Production vs. mixture velocity at different RPM's.

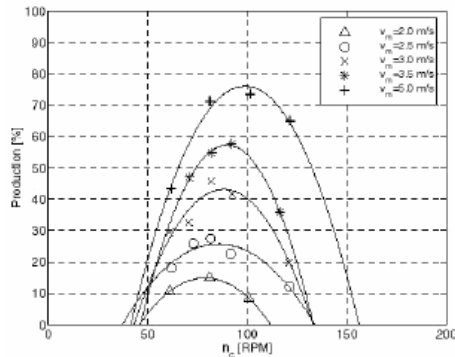

Fig. 5: Production vs. RPM at different mixture velocities

Figure 3. 24

As could be expected the results for dredging sand are quite different from dredging rock. In Figure 3. 25. The results for rock and sand are plotted against the dimensionless flow number:

$$\frac{Q}{\omega R^3}$$

The difference between two soil types is tremendously.

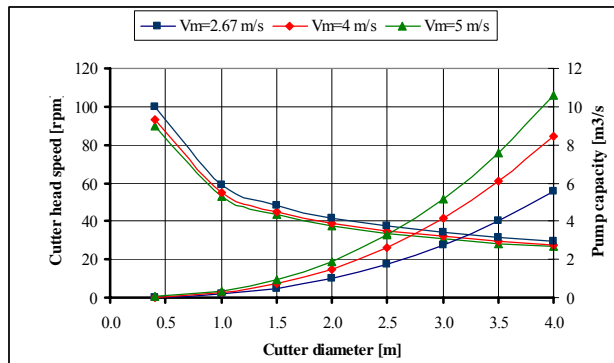

Figure 3. 25

The productivity depends except on the capacity and the cutter head speed on the particle size and the ladder angle too (Figure 3. 26) The flow numbers with the same productivity for sand at the (ladder angle also 25°) are a factor 1.5 smaller than for gravel (10 mm). This allows the use of cutter heads with a large diameters and with higher production results.

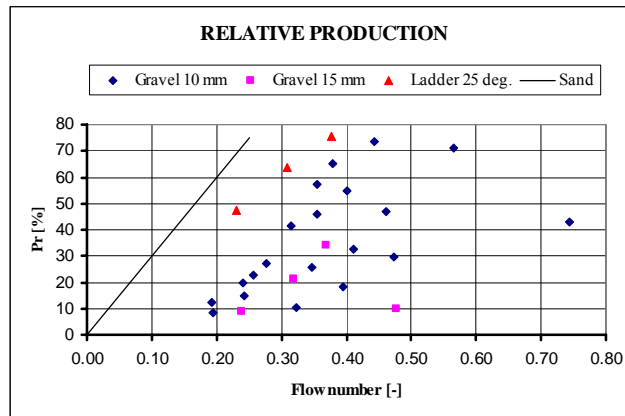

Figure 3. 26

If the cutter suction dredger is designed for dredging sand a speed of 20 revolutions per minute is adequate (see also Figure 3. 26). In silt or soft clay even lower revolutions are sufficient, provided that the cutter head does not become blocked.

3.3.2. The reaction forces on the cutter

Forces acting on the cutter suction dredge are shown in Figure 3.27. All reaction forces from the cutter head have to be transferred in a certain way the surroundings, either by the side winch forces or the spud poles to the soil or via the ladder wires and the pontoon to water. Besides that these cutting forces determines the weight of the dredger, while the forces to move the dredger through the water can have influences on the design of the dredging parts. In a ladder related co-ordinate system he cutting forces can be decomposed in the 3 dimensions; horizontal, vertical and axial.

There is a general linear relation between the 3D-cutting forces and the cutting power (Vlasblom, 1998). Furthermore the cutting forces in cavitating sand, clay and rock are almost independent for the cutting speed.

Therefore:

$\frac{F_{hor} \cdot R_{cutter}}{M_{cutter}} = c_h$, $\frac{F_{vert} \cdot R_{cutter}}{M_{cutter}} = c_v$, $\frac{F_{axial} \cdot R_{cutter}}{M_{cutter}} = c_a$ can be taken as constant for a specific soil type and relative cutting thickness $\frac{D_s}{2 \cdot R_c}$.

The horizontal and vertical cutting force

$\frac{M_{cutter}}{R_{cutter}}$ is the tangential force T as

shown in Figure 3. 28;

Both the cutting force as well as the normal force can be decomposed in the horizontal force F_h and the vertical force F_v . F_h is delivered by the side winch and F_v by the weight of the ladder or the extra draught of the pontoon. The axial force is partly taken up sideline forces, depending on the directions of those wires and partly via the thrust bearing of the cutter shaft

via the ladder trunnion transferred to the seabed via the spud pole.

Design values are for $c_v=0.9$, $c_a=0.4$ and $c_h=1$ for under cutting and $c_h=0.6$ for over cutting.

The relative thickness of the cut (d/D_c) has a considerably greater influence on the hauling force than on the vertical and axial forces.)

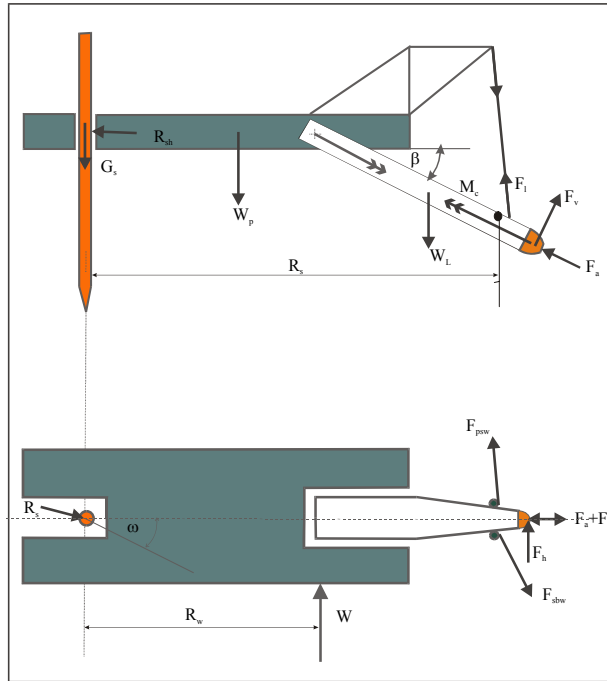

Figure 3.27

The horizontal component of the cutting force changes in direction when it passes the rotation centre of the cutter head. (Figure 3.28, Left)

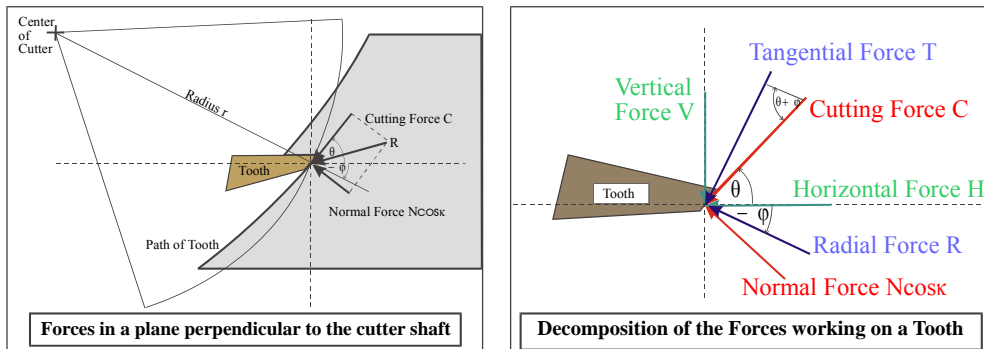

Figure 3.28

The axial force

Generally cutter heads have profiles as given in Figure 3. 29. This profile is determined by a plane through the cutter axes and the surface of revolution shaped by the teeth positions. Cutter teeth are positioned such that the centerline of the tooth is perpendicular to the contour line. This can easily be understand when the break out pattern is considered. (Figure 3. 30,right)

The normal force N can be de-composed in 2 perpendicular forces : $N\sin\kappa$ and $N\cos\kappa$, which are respectively parallel and perpendicular with the cutter axes.

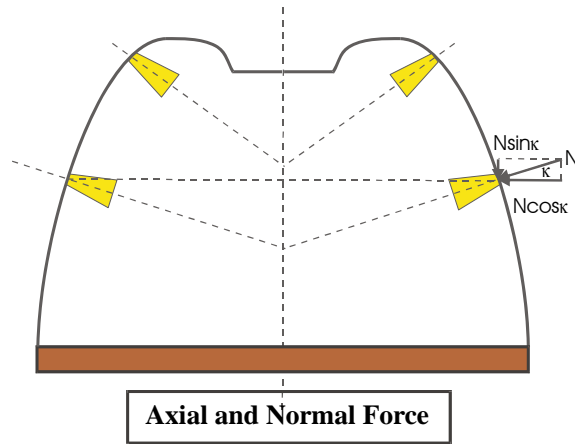

Figure 3. 29

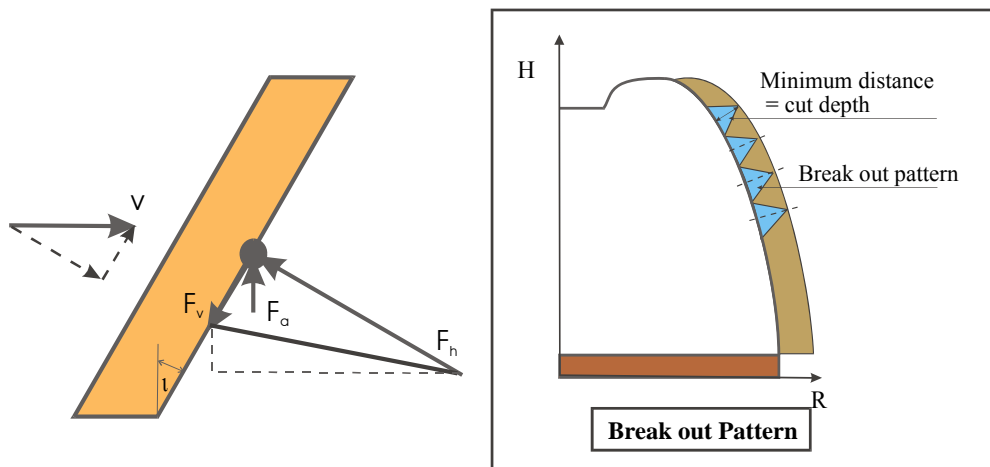

Figure 3. 30

Cutter heads with plain or serrated edges (Chapter 3.4.4) develop axial force by the helix. angle τ of the cutter head blade, which causes the so-called snow plough effect (Miedema. 1995).

In that case is the leading edge of the knife not perpendicular to direction of the movement (Figure 3. 30, left) The cutting process have to be considered in 2 perpendicular directions; one perpendicular with the cutting edge and the other parallel with it. The last one takes care for the transport of the soil in the direction of the knife. Furthermore the component of the side winch forces also gives a force in the axial direction (Figure 3.

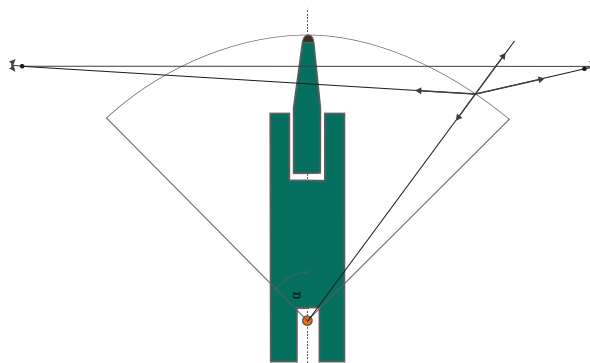

Figure 3. 31

31), depending on the position of the anchor.

As with the cutting force, the maximum forces are higher than the average forces.

The ladder weight

Following from the condition that $\frac{F_{\text{vert}} R_{\text{cutter}}}{M_{\text{cutter}}} = c_v = 0.9$ the minimum weight of the ladder can

be determined in order to fulfil the requirement that over cutting have to be possible.

Rewriting the condition and multiplying with the rotational speed ω gives $F_{\text{vert}} = \frac{0.9 P_{\text{cutter}}}{\omega R_{\text{cutter}}}$;

ωR is in the order of 4 m/s, which means that $F_{\text{vert}} \geq 0.225 P_{\text{cutter}}$

If the load on and the weight of the ladder are divided equally over the length of the ladder than the weight of the ladder $W \geq 0.45 P_{\text{cutter}}$

The mass of existing ladders is somewhat lower as shown in figure 3.39. This might be caused by an uneven distribution of the load.

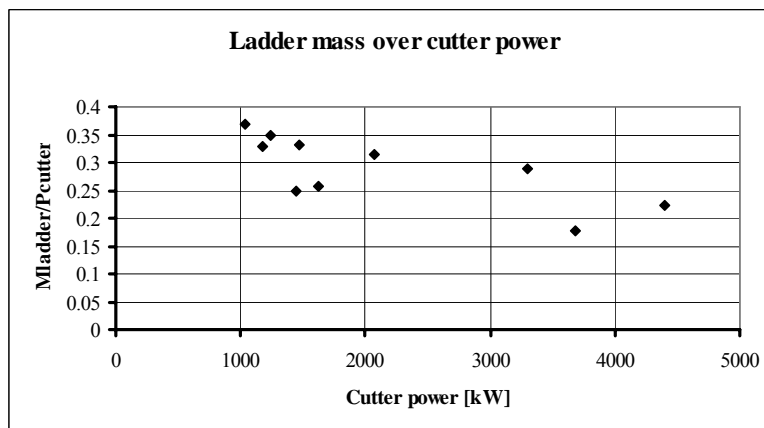

Figure 3. 32

3.3.3. The side-winch power and speed

If the relation between the horizontal force and the tangential force is assumed to be constant, then for the net side winch power:

$$\frac{P_c}{P_s} = \frac{F_c}{F_h} \frac{2\pi n R_c}{60 v_w} = \frac{F_c}{F_h} \frac{\pi n R_c}{30 v_w}$$

Symbol	Parameter	Dimension
F_c	= Tangential force	[N]
F_h	= Swing force	[N]
P_c	= Cutter power	[W]
P_s	= Swing Power	[W]
R_c	= Radius Cutter	[m]
N	= Cutter head speed	[rpm]
v_h	= Swing speed	[m/s]

For a dredger with a cutter head of radius $R_c=1$ m, a swing speed v of 20 m/min (.333m/s) and a cutter speed of 30 revolutions per minute, this gives a relation between the capacities of:

$$\frac{P_c}{P_h} = \frac{F_c \pi n R_c}{F_h 30 v_h} = \frac{F_c 30 \pi \cdot 1}{F_h 30 \cdot 0.333} = 9.4 \frac{F_c}{F_h} \text{ with } c_h=1 \text{ follows } \frac{P_c}{P_h} = 9.4$$

For a cutter head of half this size the relation is:

$$\frac{P_c}{P_h} = \frac{F_c \pi n R_c}{F_h 30 v_h} = \frac{F_c 30 \pi \cdot 0.5}{F_h 30 \cdot 0.333} = 4.7 \times 1 = 4.7$$

Here it is assumed that the relative cut thickness $\frac{D_s}{2R_c}$ is the same for both cutter heads.

This relative increase in side winch power with reducing cutter head radius is also shown in the installed power in existing cutter suction dredgers (Figure 3. 33.) Small dredgers have small cutter head radius and less cutter power.

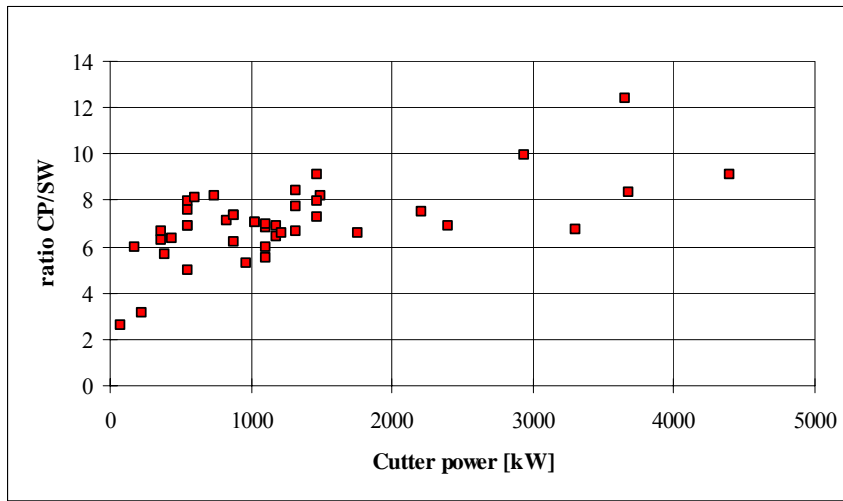

Figure 3. 33. Ratio Cutter power over Swing Power

In (Vlasblom, 1998) it is shown that the ratio of the normal force to the cutting force influences the required ratio of cutter power over sidewinch power too. For sharp teeth this ratio is 33 but decreases rapidly with increasing wear flat to a ratio of 5 for worn cutter teeth. In addition to the soil type and the revolutions of the cutter head, both the side winch power and the side winch (wire) speed depend on the dimensions of the dredger and the position of the anchor.

It should be noted that the swing force is not equal to the side winch force and the swing velocity not to sideline velocity. If F_h is the horizontal swing force to move the cutter with a speed v_c and the force in the sideline wire is F_w and de speed v_w

It can be proven that in a horizontal plane the power needed to swing the cutter head

$$P_{swing} = F_h v_h = F_w v_w = P_{winch}$$

under the assumption that the friction in the winches, blocks and motors are small.

Moreover the power required to swing the dredger around its spud depends not only on the cutting forces but also on the ladder angle α and the resistance force W to rotate the pontoon. The influence of the ladder angle is because the torque on the cutter has a de-component in the horizontal plane (Figure 3. 27). The moment to swing the dredger around the spud pole is:

$$M_h = F_h \cdot R_{sp} - M_c \sin \beta + W \cdot R_w$$

in which R_{sp} and R_w are respectively the distance from the spud to the working point of F_h and W .

M_c may be either positive or negative, depending on the direction in which the cutter head is turning.

Therefore the swing power is: $P_s = M_h \frac{v_h}{R_{sp}} = (F_h R_{sp} - M_c \sin \beta + W \cdot R_w) \frac{v_h}{R_{sp}}$

For dredging rock the influence of the force W is in order smaller than that of the cutting reaction forces.

The swingspeed v_h should be taken in relation to the production Q , because $Q = S \cdot D_c \cdot v_h$, with S the stepsize in m. and D_c the layer thickness in m.

In the position of the side winch sheave on the ladder (Figure 3. 34, Left), the relation band velocity V_z to warping direction of the side winch sheave V_p is equal to:

$$\frac{v_z}{v_p} = l\varphi \frac{\frac{k}{l} \sin \varphi - \frac{b}{l} \cos \varphi}{\sqrt{\left(\frac{k}{l} - \cos \varphi\right)^2 + \left(\frac{b}{l} - \sin \varphi\right)^2}} \quad (\text{Figure 3. 34, right})$$

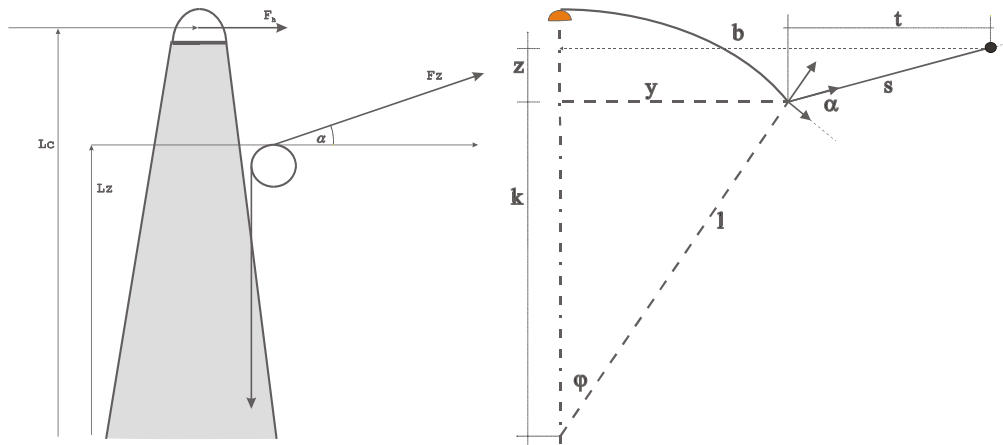

Figure 3. 34

For the cutting of rock the maximum wire velocity is 20 tot 25 m/minute. For cutting sand values of 30 tot 35 m/minute are taken.

3.3.4. The ladder winch speed and power

If it is necessary for the cutter suction dredger to dredge slopes completely automatically the ladder winch speed must be in accordance with the nominal side winch velocity. If this is not necessary the ladder winch speed may be chosen freely, bearing in mind that at low ladder winch speeds the production may be significantly affected. When, for example, the teeth of the cutter head must be frequently changed it will be necessary to raise the ladder many times. For medium large cutter suction dredgers a value of 10 m/minutes is often used. The required power is determined by the weight of the ladder and the vertical reaction forces during slope dredging in the under cutting mode.

3.3.5. The dredge pumps

To decide which pump type is appropriate for the dredger the working range of the pump capacity and pump pressure have to be assessed. Therefore the production capacity in various types of soil must be translated into:

1. The mixture capacity
2. The mixture concentration

Because:

$$Q = Q_{\text{mixture}} \cdot \frac{C_{\text{vd}}}{1 - n}$$

with:

Q	=	Production	[m ³ /s]
Q _{mixture}	=	Pump capacity	[m ³ /s]
C _{vd}	=	Transport concentration	[-]
N	=	Void ratio	[-]

The mixture capacity is determined by the mixture forming process in the cutter (see chapter 3.3.1.1)

The critical velocity required to keep the material in motion determines the minimum flow velocity and thus the pipe diameter. $v_{\text{crit}} = F_{1,H} \sqrt{2 \cdot g \cdot (S_s - 1) \cdot D}$ in which the value of $F_{1,H}$ is determined by the material to be pumped (see Section 2.2.3.3. Suction pipe diameters of lecture notes "Dredging Processes). S_s is the relative density of the solids and D the pipe diameter in m

Figure Figure 3. 35 from MTI shows practical values used in the dredging industry for the critical velocity in horizontal pipelines

The expected production is determined by the cutting power, the side winch power or the side winch velocities, depending on which is the limiting factor in the various types of soil. Using the

$$Q = Q_{\text{mixture}} \cdot \frac{C_{\text{vd}}}{1 - n}$$

together with v_{cr} gives the pipe diameter and C_{vd}

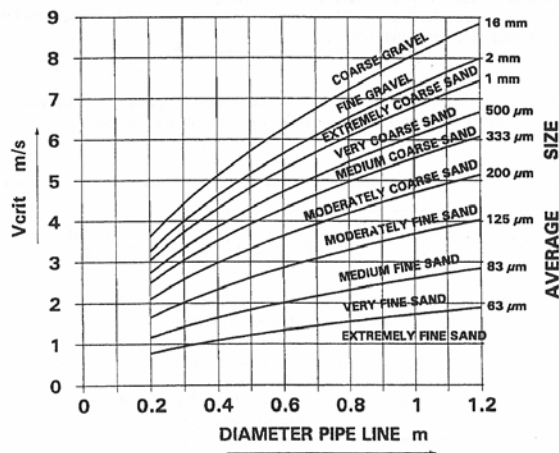

Figure 3. 35

3.3.6. The jet pump

To promote mixture forming when dredging sand some cutter suction dredgers are equipped with water jet installations. One or more jets are mounted on the sides of the ladder close to the cutter ring.

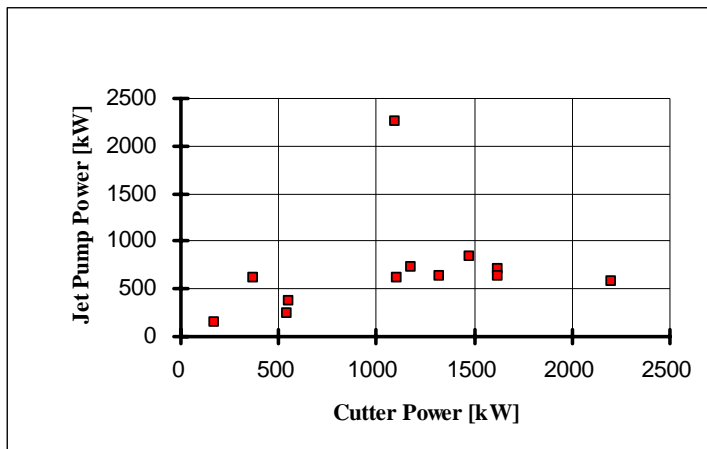

Figure 3.36. Jet pump power versus cutter power

The power needed for the jets depends strongly on the insight of the designer as Figure 3.36 shows. For more theoretical insight into this phenomena the chapter jet pumps for plain suction dredgers should be consulted.

3.4. The drives

The drives of the cutter head, the side winches and the ladder winch are either electric or hydraulic drives. Formerly the ladder winch and the side winches were combined to form a tree drum winch with one drive, which made simultaneous operation of the ladder and side winches impossible. With hydraulic systems various drives can run on the same hydraulic circuit and for this reason they can influence each other. The best choice of what may or may not run on the same circuit is important for the operation and thus finally for the production of the dredger.

3.4.1. The cutter head drive

The cutter head drive is mounted on the ladder either near the hinge side (the trunnion) or close to the cutter head. In the first case the drive and the gearbox are above water and in the second case these may be in a box under water.

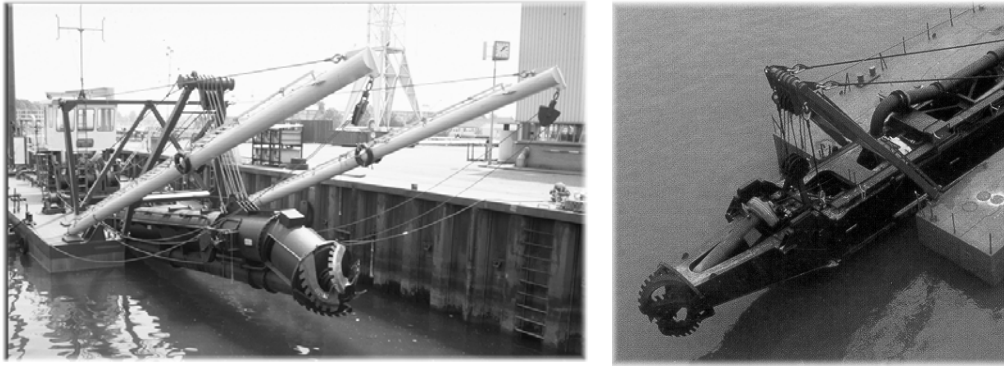

Figure 3. 37

If the drive of the cutter head is mounted near the hinge the shaft must be both long and heavy because of the high torque. This long shaft needs several ladder bearings. When the drive is mounted close to the cutter head there is more freedom to adapt the direction of the cutter head axle to the required angle, especially when dredging in shallow water.

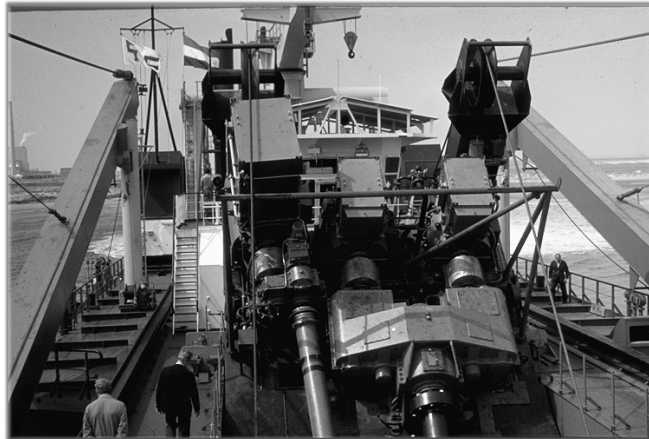

Figure 3. 38

The choice between hydraulic and electric drive depends primarily on the expected relation between the average load and the peak load. Electric drives are especially suitable because they can take overloading up to 150% without stalling (Figure 3. 39, right). This is possible because of the considerable rotation energy of the rapidly turning electric motor. As a result a flywheel effect is created. The long driving shaft also plays a role in this.

However, due to the strong dynamic character of the dredging process, gearboxes for cutter drives have to resist heavier loads than gearboxes for the all drives on board of the dredge. The dynamic cutting process and as consequence the torsion vibrations cause remarkable increase of the torque. It is even possible that due to these vibrations negative torques occur in the shaft and gearboxes with a result “hammering” of the gears. Such situation decrease the live time of the gears. Therefore gearboxes for heavy duty cutter dredgers are designed to resist a torque of 3.5 of the nominal torque. (Hiersig, 1981)

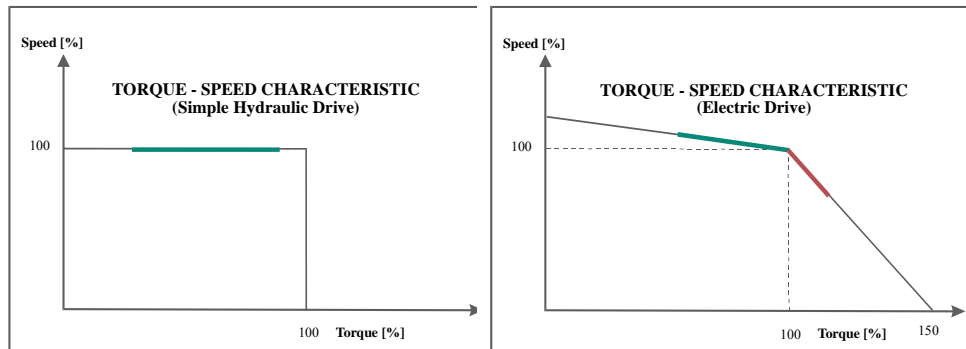

Figure 3. 39

With hydraulic drives the torque is determined by the piston displacement of the engine and the pressure in the system. When overloading occurs a safety valve which limits the pressure operates, stopping the engine. This means that the average pressure c.q torque is usually considerably lower than the maximum in the order of 60-70 % (Figure 3. 39, left). Hydraulic drives do have the advantages of being completely watertight and of driving the cutter head directly without a gearbox. Often several hydraulic drives are used simultaneously to provide the cutter head with the desired power.

3.4.2. The side winch drives

Here too, the drives may be electric or hydraulic. This choice is based on the same line of reasoning as that followed for the cutter head drive. It is not necessary that when the cutter head drive is electric the side winch drives must also be electric. The required power for the side winch drives is roughly a factor 5-10 smaller, so often secondary matters such as standardisation and price play a different role

3.4.3. The ladder drive

Because the depth of the cutter head is set with the aid of the ladder winches, the drives must be easy to regulate and must not slip when the ladder drive is not activated. The latter happens frequently with hydraulic drives as a result of leakage of the hydraulic fluid, resulting in changes of the cutting depth the dredging operation. To prevent this slipping the winch must be equipped with a break or ratchet.

3.4.4. The sand pump drives

Underwater pumps are often electrically driven. If barge loading is required with the underwater pump, it is necessary to use drives with speed control. With a fixed rate of revolution, f.i. an asynchrony ac-current motor, the variations in flow resulting from differences in concentration and grain size are often too big for the efficient loading of the barges or leads to overload of the motor.

Nowadays underwater pumps for small dredgers can also be driven by diesel engines via a pivoting gearbox. (Figure 3. 40)

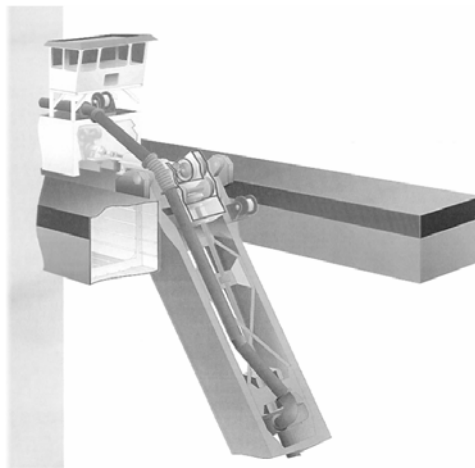

Figure 3. 40

Diesel drives are most suitable for the discharge pumps. The choice between one or more pumps and thus diesels depends on the total required pump pressure and the requirements in relation to the speed control of the diesel engines. It will be clear that when only one large pump is installed it is not so easy to control the pumping system for long and short pumping distances. Very important when using diesel drives is the type of governor. Modern governors limit the fuel injection at low revolution to avoid incomplete burning of the fuel. These governors increase the speed control of the diesel engines.

For jet pumps diesel engines or an asynchrony ac-current motor are used often. Speed control is less important for jet pumps than for dredge pumps, because of the almost fixed layout of the pipeline and the constant fluid density.

3.5. Spudsystems

The choice of the spud system plays an important part in the design of the cutter suction dredger. The spud system influences not only the layout of the pontoon, but also the efficiency of the cutter suction dredger. The most frequently used systems are the spud carriage system and fixed spuds (several other systems have been mentioned in the section on technical construction).

3.5.1. The spud carriage system

With the spud carriage system the work spud is placed in a carriage which, with the aid of a hydraulic cylinder, can travel over several metres (4 - 6 m) (Figure 3. 41) in longitudinal direction in a well at the stern of the dredger. The carriage is generally positioned in the centre of the dredger (Figure 3. 42) and is supported by four wheels on rails for the vertical forces and by guide rollers or bearing strips for the lateral forces. The cylinder is a double acting hydraulic ram.

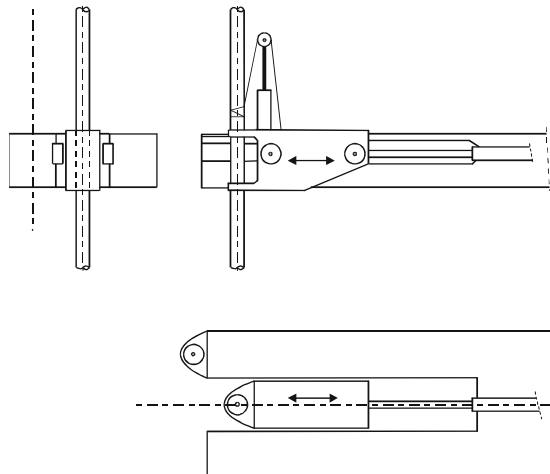

Figure 3. 41. Spud carriage

A second spud, the auxiliary spud is mounted at the stern of the pontoon, which is used to move the carriage back to its start position.

The initiation of a new cut is obtained by moving the spud carriage one step forwards. After stepping, the cutter head describes concentric circles until the spud carriage reaches the end of the stroke of the hydraulic cylinder. The return of the carriage usually takes place in the middle of a cut in the following sequence of actions. The auxiliary spud is lowered and the work spud is lifted, the carriage is moved back and then the spuds again changed. After each single swing the dredge master is "free" either to step forwards or to lower the ladder till the final is reached.

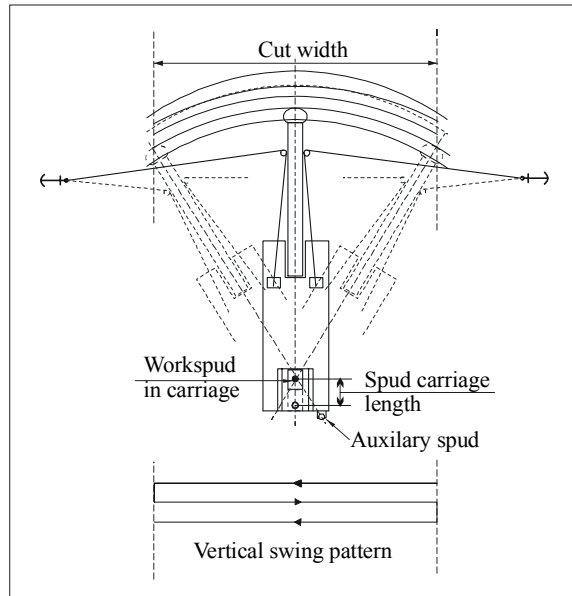

Figure 3. 42

In addition to the spud carriage in the stern well of the main pontoon of the dredger, it is also possible to have a separate spud carriage pontoon. This pontoon is fixed to the cutter suction dredger by a stiff link, usually by making use of the existing auxiliary spud carriage. This is done to change the existing, less efficient spud system or to make a wider swing (Figure 3. 43 and Figure 3. 44). It is also necessary to move the pivoting bend on the stern of the dredger to the rear of the spud pontoon.

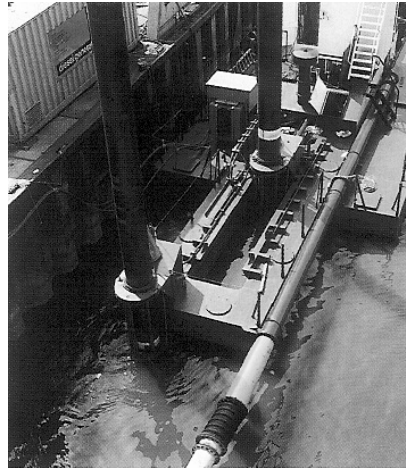
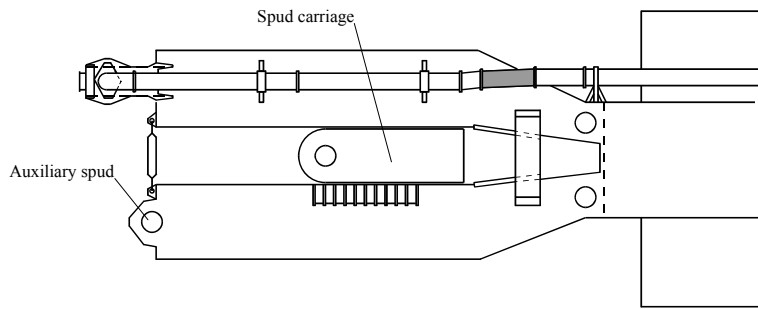

Figure 3. 43



Spud carriage pontoon

Figure 3. 44

3.5.2. The fixed spud system

When using fixed spuds both the work spud and the auxiliary spud are in fixed positions on the stern of the pontoon at equal distance from the centre line of the dredger (Figure 3. 45).

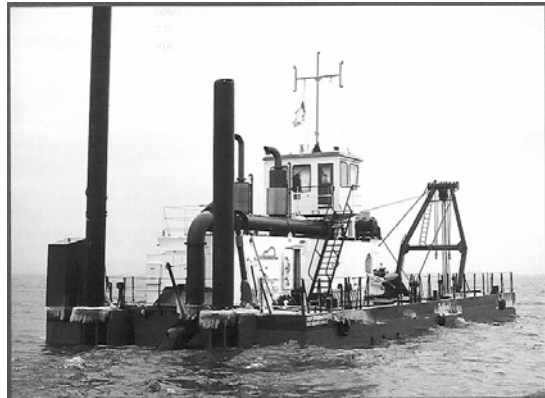

Figure 3. 45

The step or start of the cut is now initiated by letting the dredger make an angle from the centre line, then lowering the auxiliary spud and lifting the work spud.

The dredger is then swung into a symmetrical position with regard to the centre line where both spuds are changed again (Figure 3. 46).

After each single swing the ladder is lowered till the final depth is reached.

It will be clear that stepping with fixed spuds takes considerably longer than with a spud carriage, due to the down time of the swing movements.

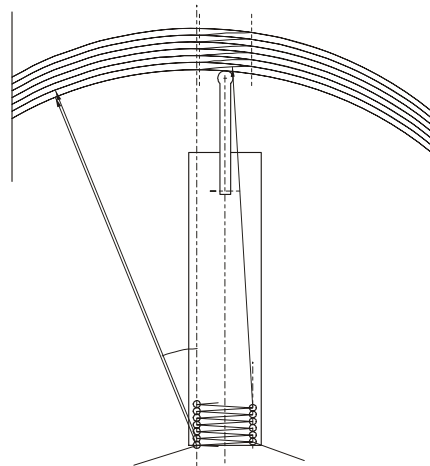

Figure 3. 46

Note that the arc is not symmetrical with regards to the centre line of the cut.

As an example the difference in effective dredging time has been worked out for a spud system with fixed spuds and one with a spud carriage. Both dredgers are the same with regard to size and power. The following boundary conditions are taken for the work:

B	Width of cut	75	[m]	<i>Time</i>	
v_s	Swing velocity	15	[m/s]	Spud carriage travel	2 min.
S	Step size	1	[m]	Spud changing	2 min.
L_{sc}	Effective spud carriage length	5	[m]	Change in swing direction incl. lifting and lowering ladder $\frac{3}{4}$ minute	2 min.
	Distance between fixed spud and cutter head	80	[m]		
	Distance between fixed spuds	10	[m]		
N_c	Number of cut layers		[-]	$=L_{sc}/N_s$	
N_s	Number of steps per carriage movement		[-]		

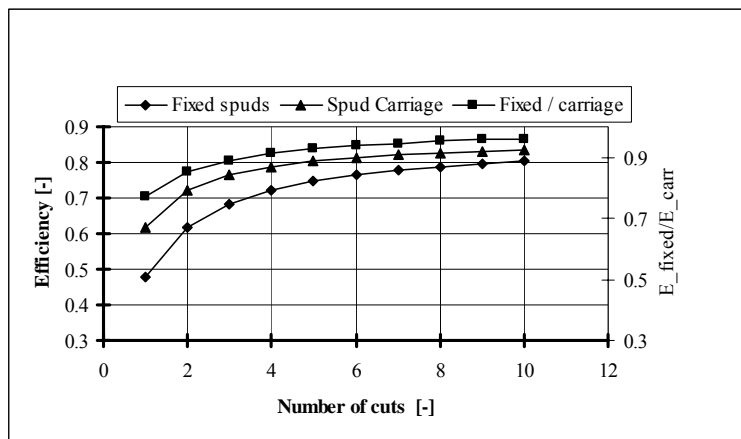

Figure 3.47 Effectiveness of spud systems

The above example (Figure 3.47) clearly shows the superiority of the spud carriage system over a fixed spud system.

3.5.3. The spud door system

For small dredger a cheaper system than the spud carriage is developed by IHC-Holland; the so called "Spud Door". In A heavily constructed door, pivoting around the auxiliary spud, is placed the working spud. The dredge pattern is the same as for the spud-carriage system, however spuds have to be changed more frequently and the accuracy is less because the working spud stays not exactly in the centerline of the dredger. The system is much cheaper than the spud carriage system.

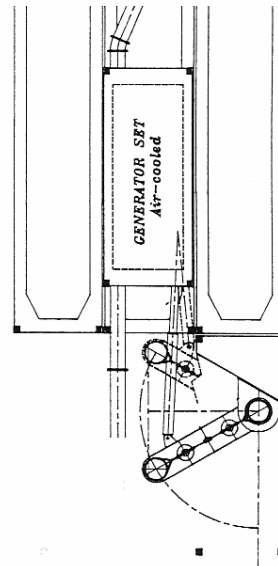
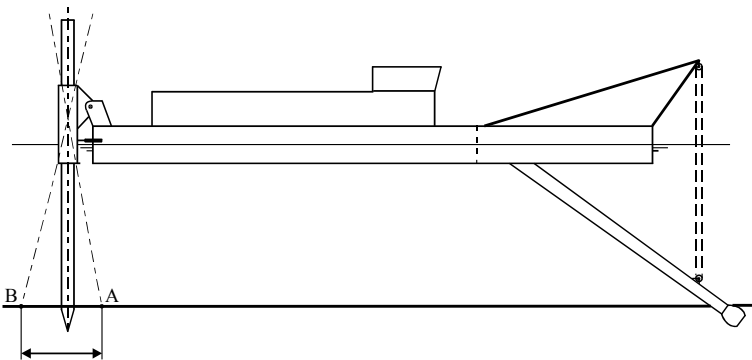

Figure 3. 48

3.5.4. The walking spud system

The walking spud system is similar to the spud carriage system with regard to the movement of the cutter head during swinging and stepping. The working spud is not in a carriage but swivels round a horizontal axis (Figure 3. 49). The step is now taken by allowing the spud to tilt to the requisite angle.

The disadvantage is immediately apparent; the maximum step depends on the depth of the water and so walking spuds are difficult to use in shallow water. The disadvantage is that it is very little or not at all cheaper than a spud carriage. The dredging pattern is similar to that with a spud carriage, while the number of spud movements is considerably larger.



Walking spud
Figure 3. 49

3.5.5. The rotor spud system

This system was already invented in the early years of 20th century. With the rotor spud system both spuds are in a rotor and stand on the ground diametrically opposite each other. (Figure 3. 50).

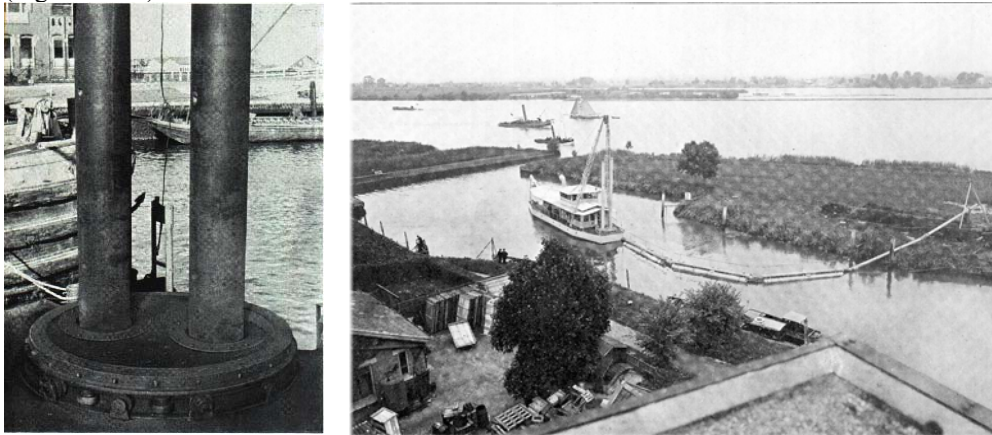

Figure 3. 50 Rotor spuds

During dredging the midpoint of the rotor remains in the centreline of the cut, so the dredger turns round the rotor. Stepping is accomplished by lifting the rear spud and turning the rotor until the rear spud becomes the front spud. The step $S=2*L*\sin(2\alpha)$, in which L is the distance between the spuds and α the angle through which the rotor turns. Using this system the dredger makes a pattern of concentric circles. The advantage of this type of system is that when stepping, only one spud has to be raised and lowered. This disadvantage is that it is very expensive, certainly for the large cutter suction dredgers. Moreover the spuds cannot be placed horizontally.

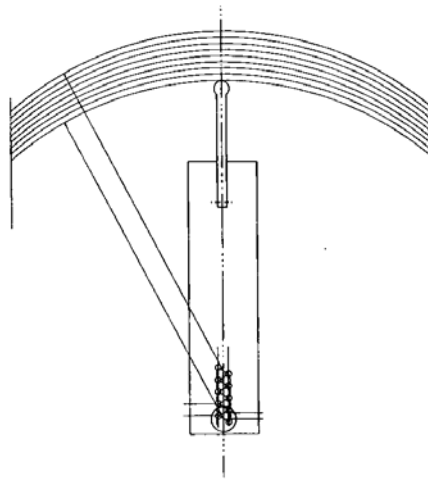

Figure 3. 51

From the point of view of efficiency, here defined as the actual dredging time in relation to total time per spud cycle, the spud wagon is the best. The number of spud changes per metre of progress is minimal. With a well-chosen cutting pattern no partly or entirely unproductive swings (warping without cutting) are needed. Likewise the rotor spud and tilting spud systems have advantages over the fixed spud systems.

3.5.6. The Christmas tree

There are situations in which anchoring by means of spuds is not possible. Such a situation arises when working at sea if the forces that waves or swell can exert on the spuds are too large. In that case one changes to working on wires. For this a Christmas tree (Figure 3. 52), a construction with wire leads, is mounted in one of the auxiliary spud carriages. With this the anchor wires meet at one point under the hull. However, in order to keep the cutter head well into the face throughout the entire swing the laterally directed anchors of the Christmas tree must stand well forward, with the disadvantage that they must be moved frequently. For this reason a bow anchor is often used.

One of the advantages is the possibility to work in deep water, but this can only be done in special cases. In a well designed cutter suction dredger the spuds are so long that they can reach the maximum dredging depth at all times, so dredging in deep water is only possible with an extension by means of a special ladder construction.

A very real advantage of working on anchors is that a considerably bigger cutting width can be achieved.

Obviously the disadvantages outweigh the advantages, otherwise the system would be more widely used. These are:

- At least three anchors must be moved.
- The freedom of movement when working on anchors is so great that it is almost impossible to dredge accurately
- This is equally true for dredging in hard soil. A star system is needed for this.

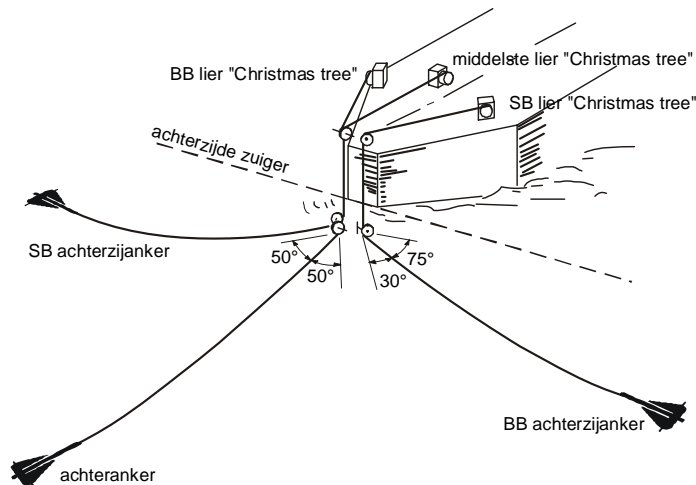

Figure 3. 52

3.6. The general layout

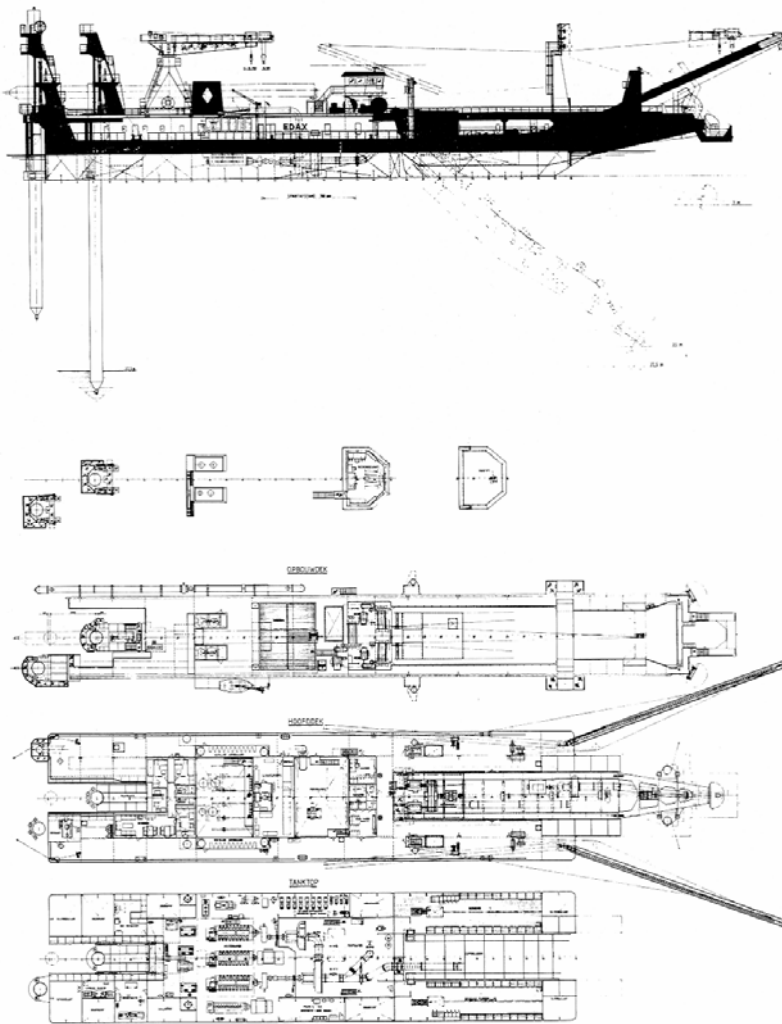

Figure 3. 53 CD EDAX

Depending on the spud system the hull may consist of a simple U-shaped pontoon (with fixed spuds) or an H-shaped pontoon (with a spud carriage system). The main dimensions; length, beam and draught of the pontoon derive from the requirements in relation to the above mentioned design parameters and the associated requirements in relation to stability and strength. Figures 3.54 and 3.55 gives design information for the pontoon.

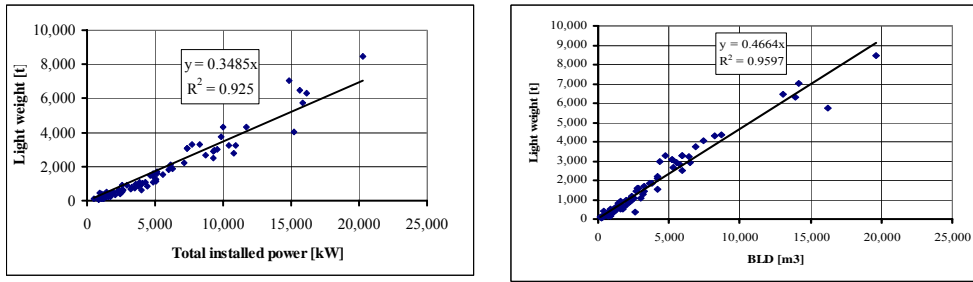

Figure 3. 54

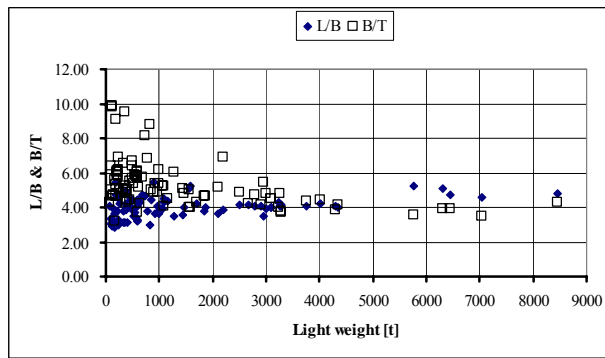

Figure 3. 55

The engine room, the pump room and sometimes in larger cutter suction dredgers, also the control room for the machinery, are located in the pontoon. In smaller cutter suction dredgers the sand pump is sometimes located on the engine room directly in front of the engine, with all the well-known disadvantages of such an arrangement.

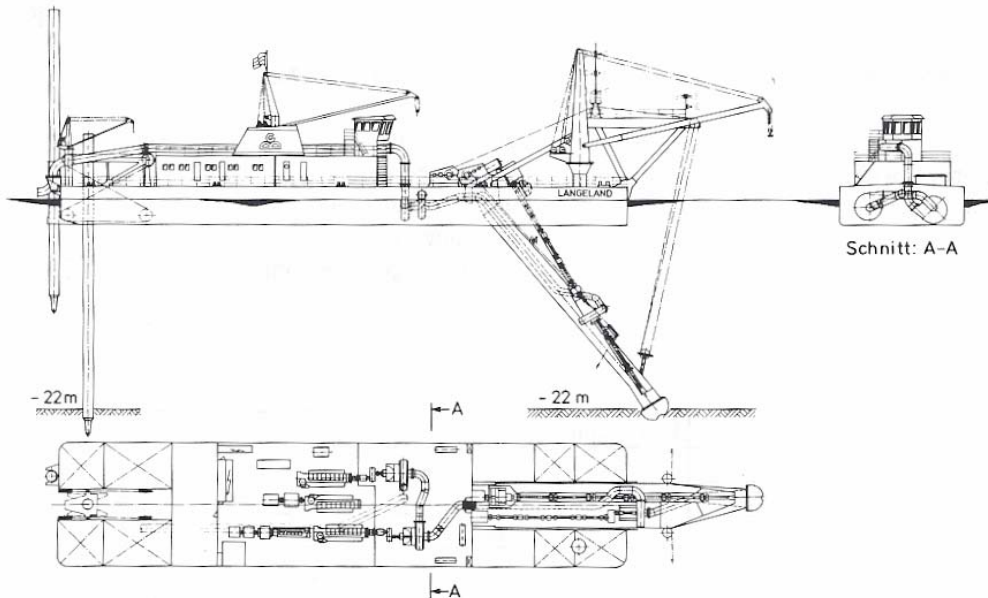

Figure 3. 56

A frequently used layout is shown in Figure 3. 56. Here the pump room is directly aft of the bow well; aft of which is the engine room. The fuel and ballast tanks are located in the side pontoons of the fore and aft wells.

The storerooms are located in the side pontoons of the forward well. The hydraulic system drives, workshops and a galley for the *local crew are often located in the side pontoon next to the well for the spud carriage. Mess rooms, toilet facilities and possibly also crew quarters are above deck.

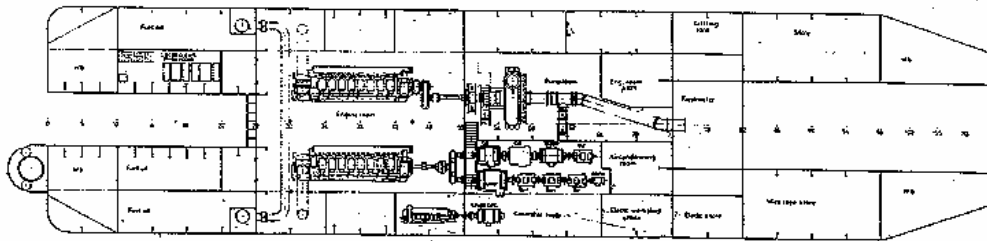
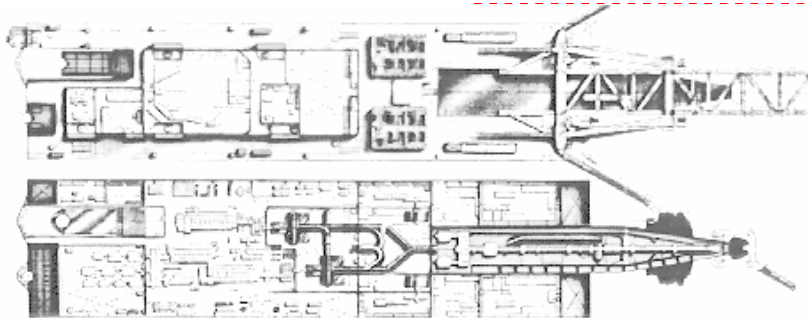

Figure 3. 57

If the cutter suction dredger has been designed to work in the tropics the generators are separated from the engine room to assist in the cooling of these machines (Figure 3. 57).



Opmerking [T1]: Ook deze figuur moet vergroot worden

Figure 3. 58

Figure 3.56 shows a dredger with the spud carriage out of the centre line of the dredger, while the cutter lead axes is the the centre line . This means that the teeth position is not optimal for both sides and as a consequence this will result in more teeth wear.

Self propelled cutter suction dredgers have a more complicated layout resulting from the two possible modes of working; dredging and sailing. The propulsion mechanism can be located at the ladder end (CD Taurus, CD Marco Polo, CD da Vinci) or at the spud end (CD Ursa, CD Oranje). In the second case the dredger sails with the ladder at the front and port and starboard is the same for both sailing and dredging. Moreover the propellers are directly driven by the main engines. This is not possible in the first case, so the propellers are powered by electric motors. The layouts described are therefore self explanatory (Figure 3. 59).

Opmerking [T2]: Tekening van een zelfvarende snijkopzuiger

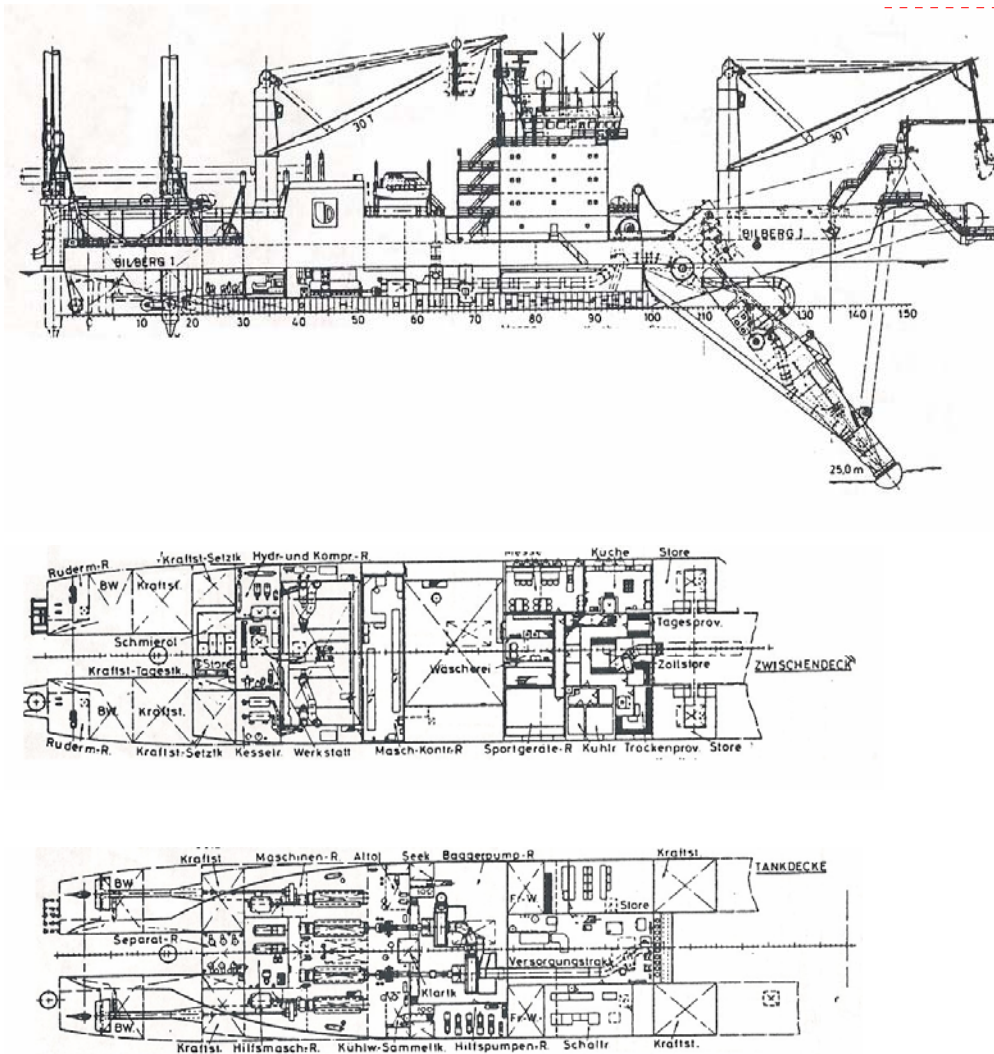

Figure 3.59 Self propelled cutter suction dredger "Ursa", built in 1986

Small to medium sized (to 3500 kW) cutter suction dredgers are often used to make roadbeds. To permit overland transport to the sand extraction area these dredgers are demountable. Because of the need for strength, the main pontoon in which the pump and diesel engine are located is usually constructed as a single unit. When designing demountable dredgers it is necessary to consider how the parts of the dredger will be transported by road or over water. In the first case the maximum size of the pontoons is determined by the permitted size and weight for road transport. For smaller dredgers the pontoons are made up of 40 or 20-foot containers, while the other parts are of such size that they can be carried in containers.



Figure 3. 60 Beaver 1600 on 5 trucks

Opmerking [T3]: Deze figuur is veel te onduidelijk

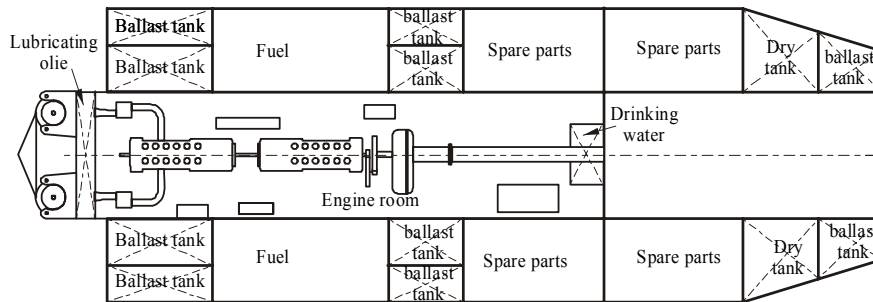

Figure 3. 61

In demountable dredgers also, the pump room and the engine room are located one behind the other in the main pontoon and the ballast tanks and storerooms are in the side pontoons (Figure 3. 61). With containerized dredgers the entire vessel is built up out of containers. In this case the pump and motor are often in a container “on deck” (Figure 3. 62).

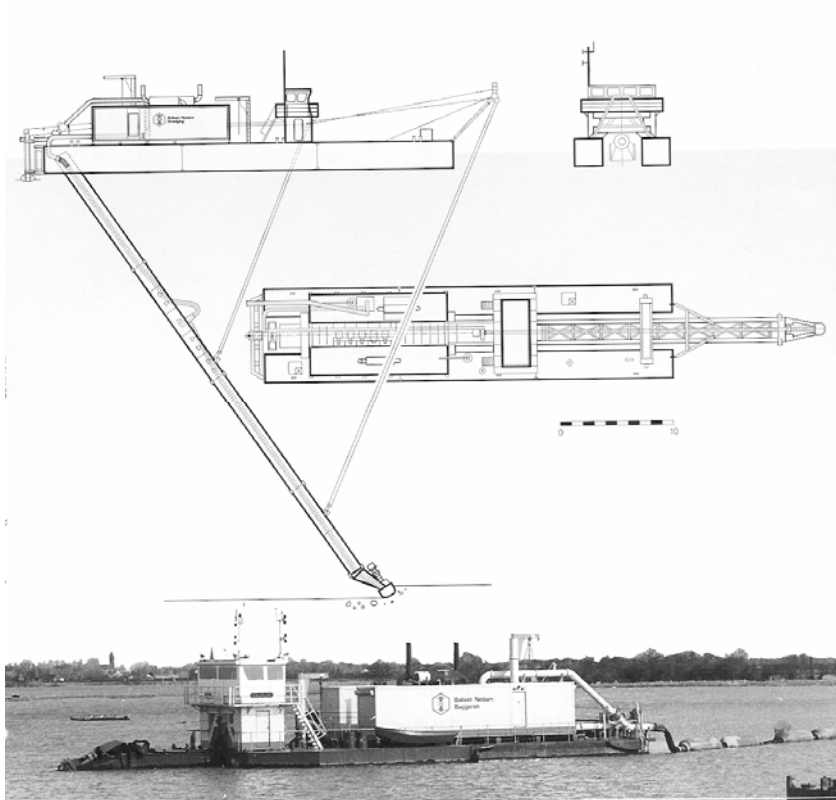

Figure 3.62 Containerised Dredger

3.6.1. The Hull

The floating capacity of a stationary cutter suction dredger derives from the pontoon that is constructed as a single unit (mono-hull or mono-pontoon) for most large cutter suction dredgers and, for demountable cutter suction dredgers, consists of several pontoons. The pontoons beside the ladder well are often chamfered to form trapezoids in order to limit the minimum width of cut.

It is essential that there is a separate pump room: if the pumps were located in the engine room a leakage or an error during inspection of pumps might result in the flooding of the engine room with a good chance of the dredger sinking. The pump room should be designed in such a way that, when flooded, the dredger doesn't sink. Furthermore the pipeline system must be designed in such a way that the flooding of the pump room can be kept to a minimum.

Consider therefore:

- a remote controlled valve behind the well bulkhead. This is necessary for the changing of the rubber suction hose
- a bilge alarm.

In designing the hull it is necessary to take into account that a part of the reaction forces from the dredging process must be transferred to the work spud via the hull. For this reason the main pontoon of demountable dredgers is constructed as a single unit. This means that the ladder hinge and spuds are mounted on the main pontoon, so the side pontoons as well as the links to the main pontoon are not so heavily loaded.

The ladder gantry spans over the forward well as a simple A-frame, a frame construction or a frame in the form of a box girder construction. When dredging in 'undercut' the vertical forces are transferred to the pontoon via the gantry.

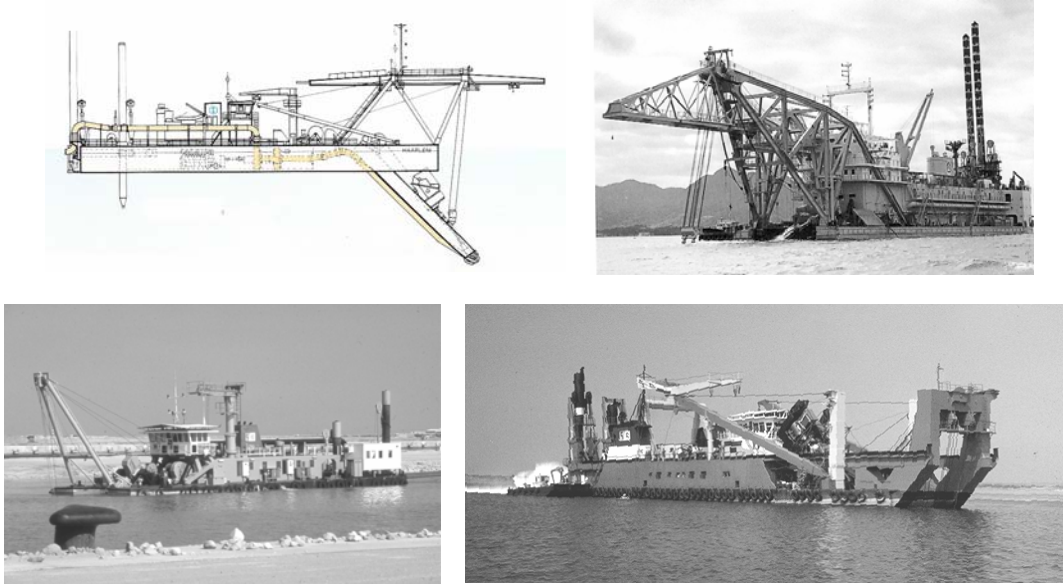

Figure 3.63 Different ladder gantries

3.6.2. The cutter head ladder

Originally the cutter ladder, or cutter ladder was constructed as a frame girder with two longitudinal girders consisting of steel beams connected to each other by many transverse beams and struts. The name cutter ladder derives from this structure. The transverse beams were used as supports for the cutter shaft bearings.

The ladder that is located in the forward well is hinged (the trunnion) on one end to the pontoon and a tackle and ladder wire to the ladder gantry suspends the other end. The ladder wire runs via the ladder gantry and various sheaves to the ladder winch to adjust the desired depth.

Because owing to the transverse forces it is essential for the ladder of a cutter suction dredger to be stiff, for the large cutter suction dredgers a double box construction is used, strengthened by longitudinal and transverse links. Furthermore this has the advantage that the ladder is given sufficient weight. This weight is needed in order to swing the cutter head to both sides. If the ladder is not heavy, as in the case of small cutter suction dredgers, extra arrangements must be made. For example the cutter head drive can be mounted as close as possible to the cutter head. Lead is often added close to the cutter head. For very heavy cutter suction dredgers the requirement of the stiffness may exceed the demand for sufficient underwater weight. In this case the ladder is equipped with floats.



Figure 3. 64 Boxtype cutter ladder

In small cutter suction dredgers the ladder is often built up from basic elements. The ladder is supported by pins that are fixed to the ladder and rest in bearing houses that are rigidly fixed to the pontoon.

The drive of the cutter head is either at the top of the ladder, thus at the hinge side or below near the cutter head. In the first case the drive and the gearbox remain above water and the cutter head is driven by a long shaft, sometimes tens of metres long. Because of the high torque demanded by the cutter head this shaft has a considerable diameter. The shaft has supported at various points and must, especially in the case of heavy cutter suction dredgers, be on the centreline of the ship.

The end bearing, (Figure 3. 66 and Figure 3. 66) close to the cutter head is made of rubber and lubricated by water. The axial forces are taken up by a pressure bearing that is mounted in the gearbox.

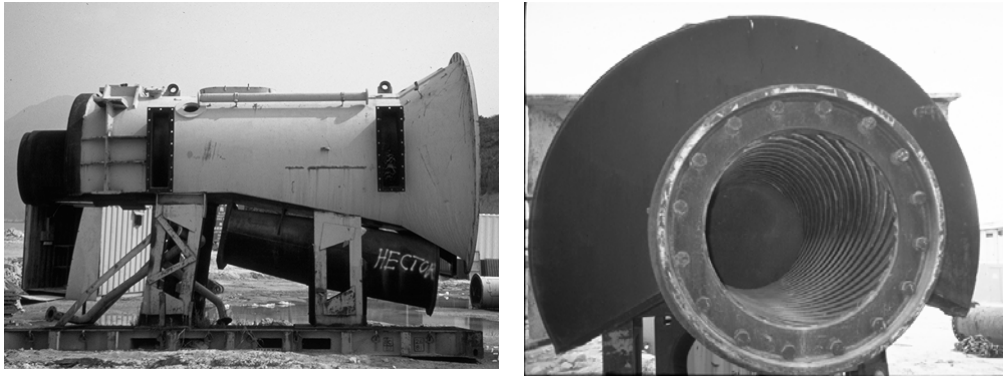

Figure 3.65 Rubber end Bearing

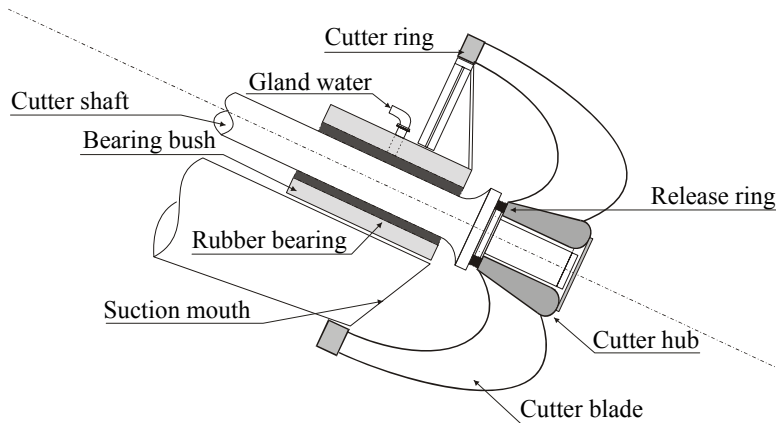

Figure 3.66

3.6.3. The cutter head

The production of the cutter suction dredger is largely determined by the cutter head. Its type and size depend not only on the technical specifications of the cutter suction dredger, including cutting and side winch power, cutter revolutions and the weight of the ladder, but also on type of soil to be dredged. With relatively high side winch forces and a small cutter diameter, higher cutting forces can be generated and thus harder soil can be cut. In contrast, with the same cutter power in soft ground it is necessary to use a bigger cutter diameter and exchange the high side winch forces for a higher speed by changing the gears of the side winch drive. When cohesive soil is being cut different boundary conditions play a role, for example, the need to avoid blocking the cutter head.

General guidelines for cutter heads for various types of soil.(Figure 3. 68):

- **for hard soil.** Suitable to withstand impact forces on one or more teeth, thus heavy and robust. Small in contour with replaceable teeth. Can withstand extreme wear on both the cutter head itself and on the teeth and adapters. Good, accurate tooth positions. The size of the fragments may not exceed the minimum passage of the pump.
- **for non-cohesive soil.** Suitable for very high production rates Good mixture formation required. Many replaceable chisels (wide or narrow) or cutting edges. Wide though flattened contour (little pumping action). Well able to withstand wear, especially of the cutting elements. Here also good, accurate tooth positions are needed.

- **for cohesive soil.** The cutter head may not become blocked, so is ample and round in contour. Open near the hub. Often with one less blade (thus 5 blades). Good cutting properties in clay, small fragments. Plain or serrated edges or many small teeth.

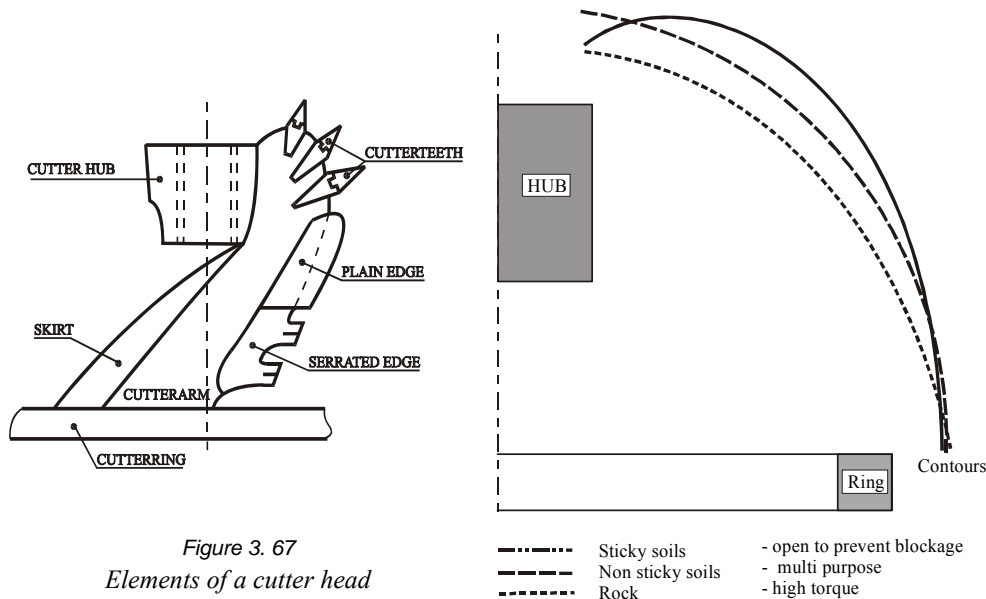

Figure 3. 67
Elements of a cutter head

Figure 3. 68 Cutter head contours

Although it is better to use a different type of cutter head for each type of soil, cutter heads are marketed that can be used in more than one type of soil. The so-called ‘multipurpose cutter’ is a compromise with regard to contour.

A cutter head is comprised of the following parts (Figure 3. 67).

- The back ring, that is the ring on the underside of the cutter head. The inside diameter of the ring is such that this fits the suction mouth and or the cutter shield (Figure 3.66).
- The hub by which the cutter head is mounted via an ‘Acme’ or three threaded screw onto the cutter shaft. The distance between the underside of the ring and the underside of the hub is termed the set height.

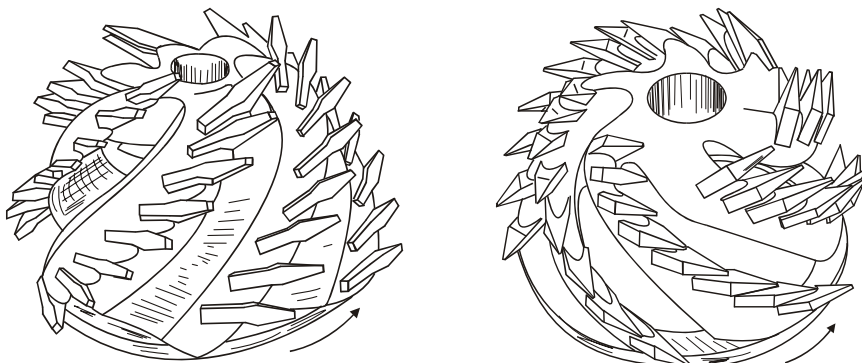

Figure 3. 69

- The cutter arms or blades, usually 5 or 6. The number is related to the required strength and/or space between the arms. The cutter arms form a screw shape and link the ring to the hub. The cutter head is termed a normal helical cutter head if the chosen screw shape is such that the dredged material is transported to the ring. (Figure 3. 69 left) If the thread of the screw runs in the other direction the cutter head is termed a reverse helical cutter (Figure 3. 69 right).
- Edges (knives) or replaceable teeth or chisels are mounted on the cutter arms. The tooth is attached by means of a locking pin to an adapter that is fastened to one of the blades. In hard soil a six bladed cutter head is often used with teeth on the even blades that are offset in relation to those on the uneven blades. This is termed 'staggered mounting'.
- The turning direction of a cutter head is defined when looking from the control cabin towards the cutter head; that is against the underside of the ring.
- The passage through the cutter head increases towards the ring. This may cause blockages in the pump if fragments that are too large for the pump can be taken up. The passage through the cutter head is sometimes reduced by the addition of skirts, which are welded onto the blades to extend the cutter arms (Figure 3. 70). The passage can also be reduced by the welding of plates perpendicular to the blades (Figure 3. 70).

Opmerking [T4]: Page: 37
foto de Heer II blz 121

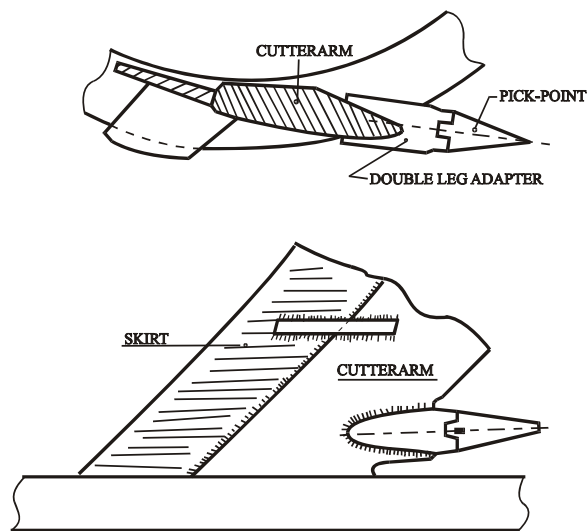

Figure 3. 70

Besides the turning direction the height H between the under side of the hub and underside of the ring, the internal ring diameter D_i and the type of tread in the hub are the important data for mounting the cutter well on the shaft and ladder. (Figure 3. 71)

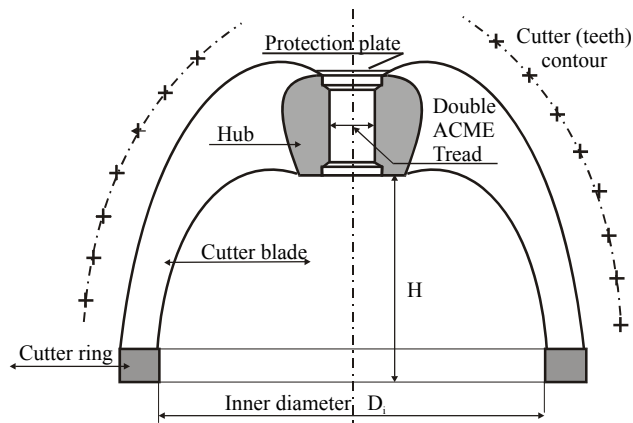
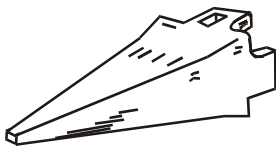

Figure 3. 71

3.6.4. Tooth and cutting edge systems

There are various tooth and cutting edge systems on the market, each with its own advantages and disadvantages. They are all based on the principle that it must be possible to quickly replace the parts that are subject to heavy wear. In addition to the property mentioned above, a tooth must satisfy the following requirements:

- There must be a good transfer of the cutting force to the cutter arm.
- The positioning of the teeth and adapters must be such that there is little or no wear on the cutter arms. The blades must therefore run freely.
- Mixture formation in the cutter head is promoted.



"PICK-POINT"

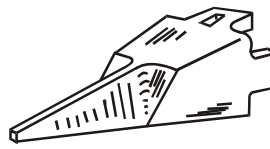

TRAPEZOIDALE PICK-POINT

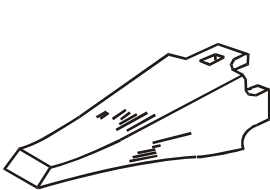

NARROW CHISELS

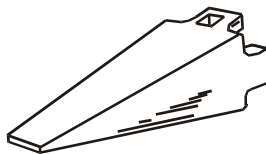

WIDE CHISEL

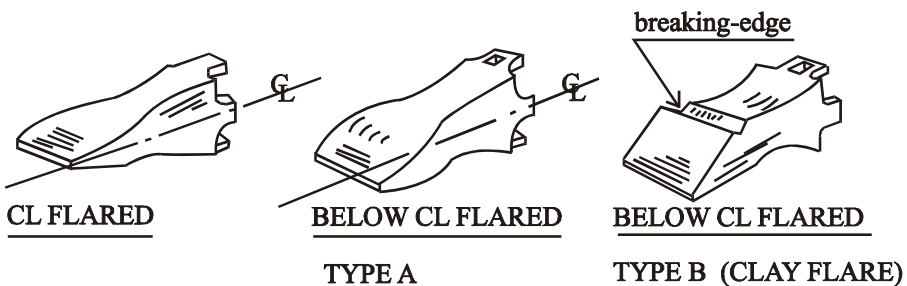

Figure 3. 72

As shown in Figure 3. 72, there is a wide range of types of tooth and chisel. The use of the specific type of tooth depends on the strength of the soil.

- pick points short : hard rock

- “ “ long : rock
- “ “ trapezoid : soft rock
- chisels narrow : cemented sand
- “ wide : sand and loose soil
- “ flared : clay

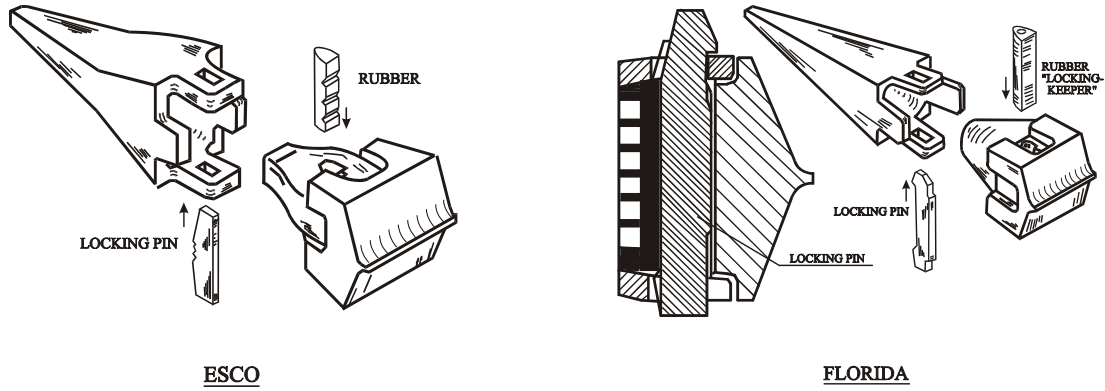

Figure 3. 73 Tooth Systems

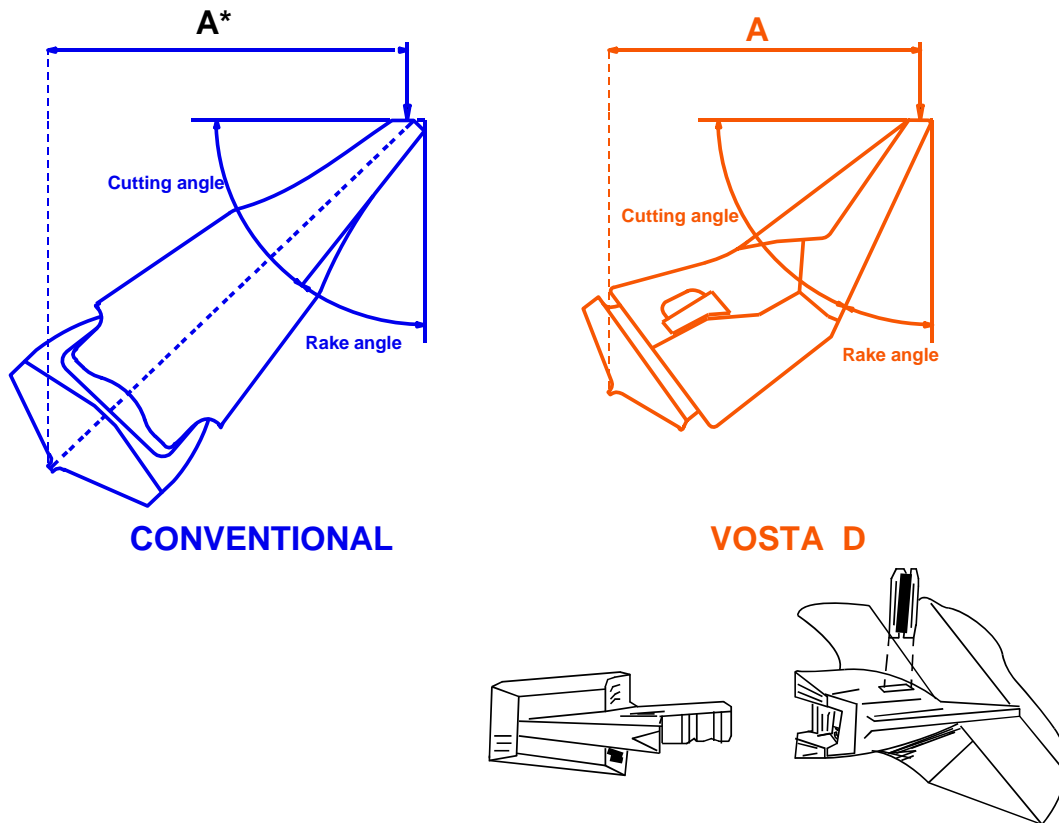

Figure 3. 74 Vosta tooth System

The best known systems are:

- Esco (Figure 3. 73 left)
- Florida (Figure 3. 73 right)
- Vosta (Figure 3. 74)

The first two types are very similar to each other.

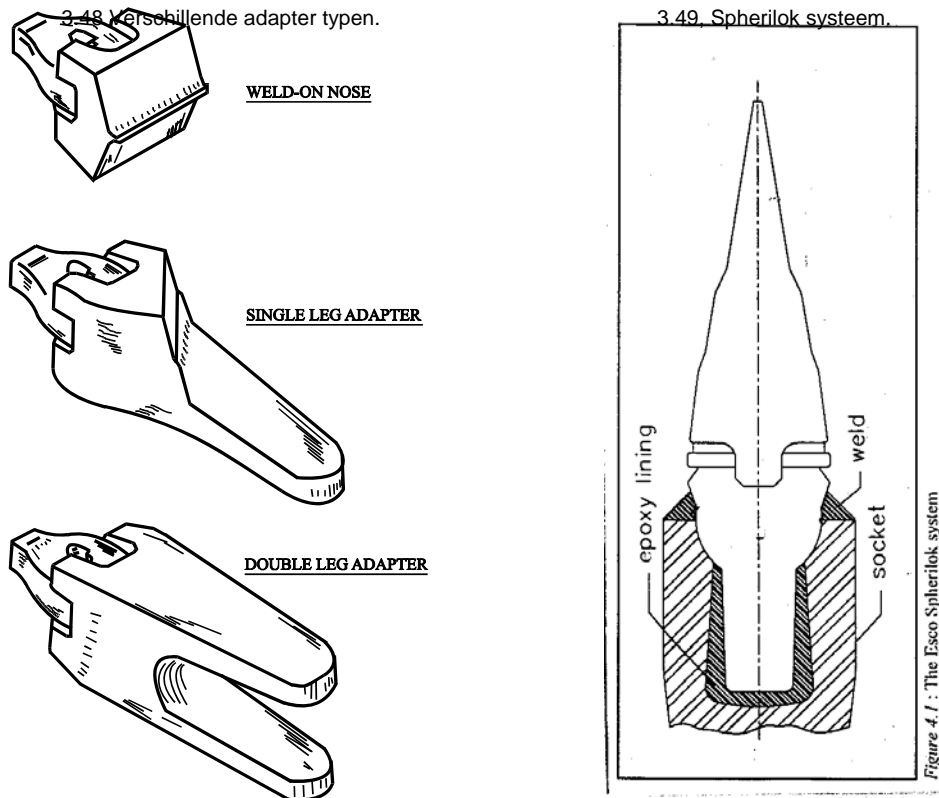

Figure 3. 75 Adapter systems

The difference lies in the fitting of the tooth and the adapter (Figure 3. 73). Four types of adapter can be distinguished of both systems, these being:

- the weld-on adapter
- the single-leg adapter
- the double-leg adapter
- the Spherilock adapter

From above downwards these adapters have a reduced grade of freedom in positioning. On the other hand the chance of incorrect positioning during repairs also decreases.

There is a wide variation in the types of teeth and chisels used by these systems, depending on the material to be dredged. The adapters take up the cutting force, which implies that there must be a good fit between the tooth and the adapter, in other words the tooth must not be loose. The joint is secured with a locking pin, which is prevented from falling out by a flexible rubber locking keeper.

The Vosta system is clearly different from the Esco and Florida systems (Figure 3.73).

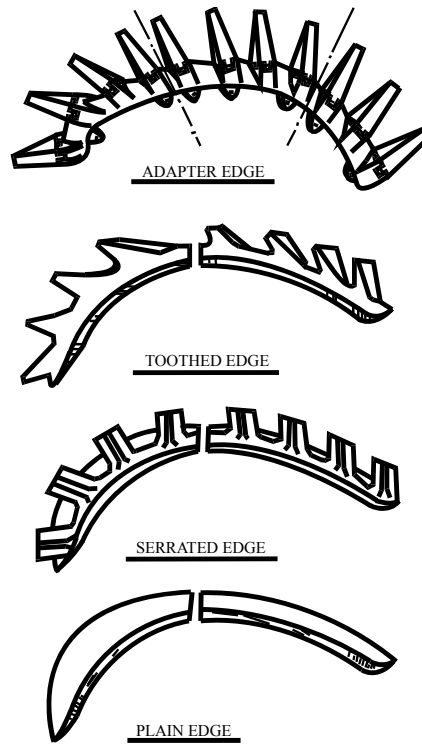

Types of cutter knives.

Figure 3. 76

In addition to cutter heads with replaceable teeth or chisels there are also cutter heads with cutting edges. The edges welded directly onto the cutter arm of the cutter head, with or without a fitting lip (see Figure 3. 76) Such types of cutting edge are suitable for various types of. edges.

The main shapes are :

- plain edges : for various types of soil
- serrated edges : for clay
- toothed edges : for hard clay
- adapter edges : for hard clay

These edges can also be obtained as projecting offset edges. In this case the plane of the edge forms an angle with the cutter head arm. This prevents material such as clay from sticking to the arm.

3.6.5. The side wires

As said, the dredger is moved over the width of the cut by hauling on one of the side wires while at the same time paying out the other. The side wires run from the side winches via the side wire sheaves to the anchors

The side wire sheaves, which are fastened at the lower end of the ladder must be able to adjust to the angle that the side wire makes with the plane of the horizontal, because the anchor is not usually at the same level as the point of attachment of the side wire to the ladder. The position of the side wire sheaves and the anchor determines not only the force in the side wire, but also the speed at which the cutter head moves. (Figure 3. 77)



Figure 3. 77 Side wire sheaved in upwards position

The side line winches can either be placed on the ladder or on the pontoon. Some heavy duty cutter suction dredgers have double drum winches (Figure 3. 78). The side line wire is first laid over a grooved drum with a relative small diameter to a drum with a bigger diameter. On the grooved drum sufficient wire length can be stored to swing over a full cut width. On the big drum additional wire can be stored.

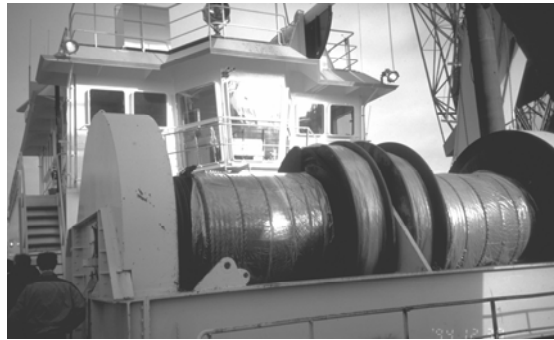

Figure 3. 78



Figure 3. 79



Figure 3. 80

Figure 3. 79 shows the sheaves on the ladder to guide the side wires to the winches on the pontoon and Figure 3. 80 hydraulic winches on a Beaver Dredger.

3.6.6. The anchor booms

Anchors can be moved by a floating crane, assisted by a flatboat. To keep anchoring movements to the minimum, they are dropped as far as possible from the dredger. Modern cutter suction dredgers are often equipped with anchor booms, which makes it possible for the skipper to move the anchors without outside assistance.

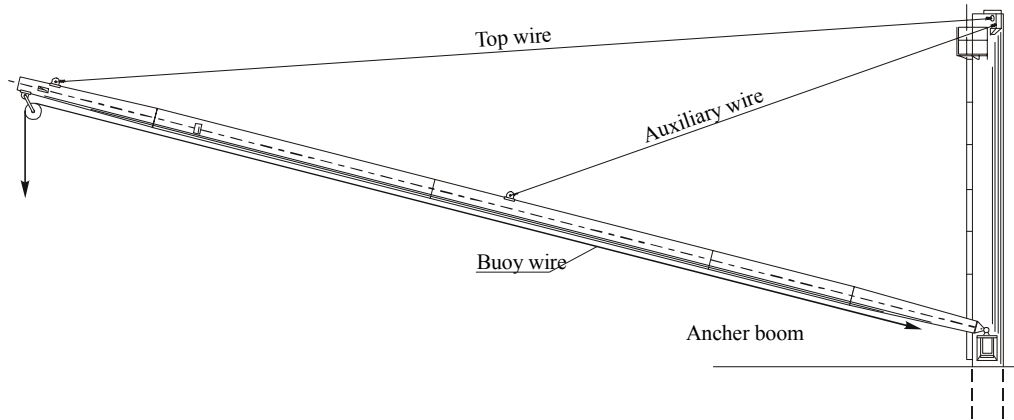

Figure 3. 81 Anchor boom

The anchor booms are placed on the bow pontoons at the point where the chamfering starts (Figure 3. 82) and fastened to the deck by a pivoting construction. Each anchor boom is fastened by one or more wires to a frame or, as is often seen, to the ladder gantry.



Figure 3. 82 Al Mirfa changing her anchor position

The anchor boom can turn on its pivoting construction by means of the anchor wires which are fixed to the top of the anchor boom and which run via a series of sheaves to the anchor winches. The anchor wire, which is used to pull up the anchor, runs from the anchor to the top of the anchor boom via the anchor boom downward and then via a set of sheaves to the anchor winch.

3.6.7. The spuds

The spuds are fastened via spud doors to the spud carriage or the pontoon.

Because the spuds are loaded on a bending moment the wall thickness increases with the stress level (Figure 3. 83 right). To obtain a good penetration into the soil, the lower ends of the spuds are pointed. In hard soil the spud is often dropped in free fall and needs therefore a massive point (Figure 3. 83 left)

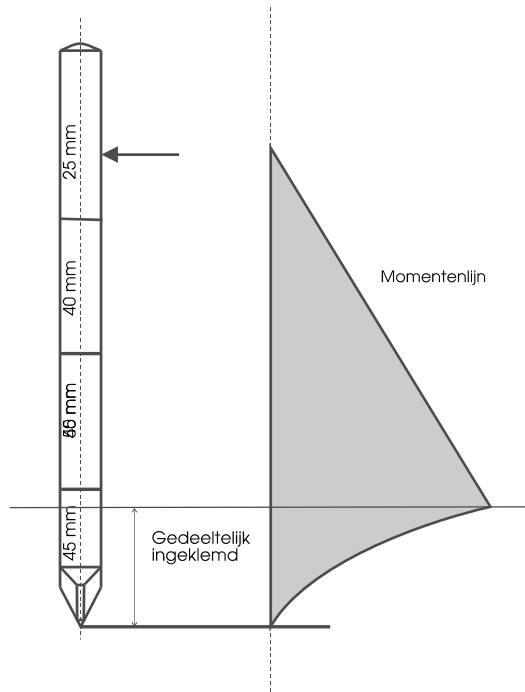

Figure 3. 83

In soft ground, on the other hand, the spuds are set down to prevent them from sagging too far into the ground.

During transport the spuds must be carried horizontally, so most cutter suction dredgers have special equipment for this purpose.

3.6.8. The spud lifting system

In order to move the dredger, the spuds must be lifted and various systems for this are in use. The simplest method is one in which the spud is hoisted by means of a wire attached to the upper end (Figure 3. 84 .a). This method is often used by American cutter suction dredgers and has the advantage of simplicity and accessibility when wires break.

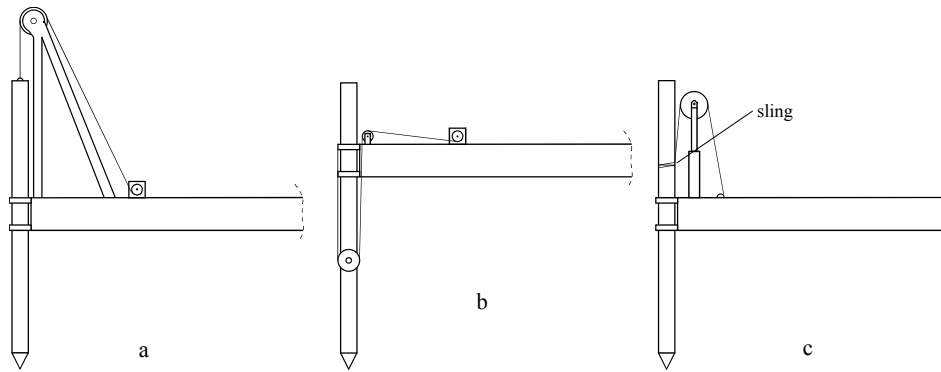

Figure 3.84 Spud Lifting systems

The great disadvantage is the high construction height needed to lift the spud in this way. It is also difficult to extend the spuds, should this be necessary. In order to avoid this disadvantage the spud can be hoisted on a wire that runs through a pulley mounted on the underside of the spud (Figure 3.84.b). Although this is still a simple construction it has the disadvantage that when a wire breaks it is not easy to thread the new wire through the pulley and it is necessary to use either a diver or a crane.

Many cutter suction dredgers lift their spuds by means of a sling, which is clamped round the spud by the tension in the hoisting wire. The hoisting wire runs over a sheave that is attached to a double action cylinder above and which runs down to a fixed position on deck. The spud is then hoisted by extending the cylinder (Figure 3.84.c). This construction has the advantage that all the parts are easily accessible and it is not a high structure. Moreover the spud can fall freely because the sling is self releasing. The disadvantage is that the lifting height is restricted by the stroke of the cylinder. In that case the spud must be taken over. For this reason the spud has holes through which pins can be pushed so that the spud remains suspended on the auxiliary carriage.

3.6.9. Pumps and pipelines

The suction pipeline

The suction mouth is mounted under the end bearing and opens into the cutter plate/shield (Figure 3.85).

The area of the suction mouth is usually a little bigger than the area of the suction pipe ($1.2/\text{suction pipe}$). In some cases the suction mouth is not symmetrical but somewhat turned in the turning direction of the cutting head. This gives less spillage when over-cutting (cutter head turning in the direction of swing).

The suction pipe must be mounted in or under the ladder in such a way that parts can be easily changed.



Figure 3.85 view on suction mouth of CSD Ursa

The connection of the suction pipe on the ladder to the pipeline in the ship must be flexible because of the pivoting movements of the ship. Often a suction hose is used. This is a heavy cylindrical rubber hose with steel rings embedded in the rubber to prevent it from collapsing when under pressure occurs.

When dredging in coral or coral-like types of rock, suction hoses cannot be used owing to the sharpness of the fragments of coral that cut the rubber. In such cases a ball joint from a floating pipeline forms the link. The angle through which the ladder rotates is then usually more restricted than when a suction hose is used. It is also recommended that an extra suction pipe be placed in front of the first on board pump through the bottom of the hull. When using long discharge pipelines this extra suction pipeline makes it possible to raise the ladder, for example to inspect the teeth, while the pumps are still being used to clean out the discharge pipeline.

The pumps

For cutter suction dredgers without an underwater pump the suction pipelines should be kept as short as possible and the position of the first pump should be as low as possible under the waterline. Where the suction pipe emerges above water the chance of air being sucked into must be minimized. (The taking in of air has the same effect as cavitation.) Besides good discharge characteristics the first pump must also have good suction characteristics. In other words a high vacuum limit and/or low NPSH-value.

If the dredger is equipped with an underwater pump the layout is less critical and factors such as accessibility for inspection and repair play a more important role. The inboard pump requires only good discharge characteristics. If there is more than one inboard pump on board the layout must be such that, if desired, the ladder pump and **one** of the inboard pump can be used. All pumps must have an inspection hatch so that the pump and impeller can be inspected and, if necessary, to remove debris.

3.4.4.1 The discharge pipeline

The pipeline runs from the pump room high above the deck to the stern (Figure 3.57). In the pipeline on board are:

- an expansion joint to take up possible changes in length.
- a gate valve in case it is necessary to prevent water from running back from a higher-level disposal site.
- an air release valve
- a suspension bracket from which lower bend can be suspended and still rotate.
- a lower bend with a ball joint to which the floating pipeline can be attached. A suction hose may be used instead of a ball joint.

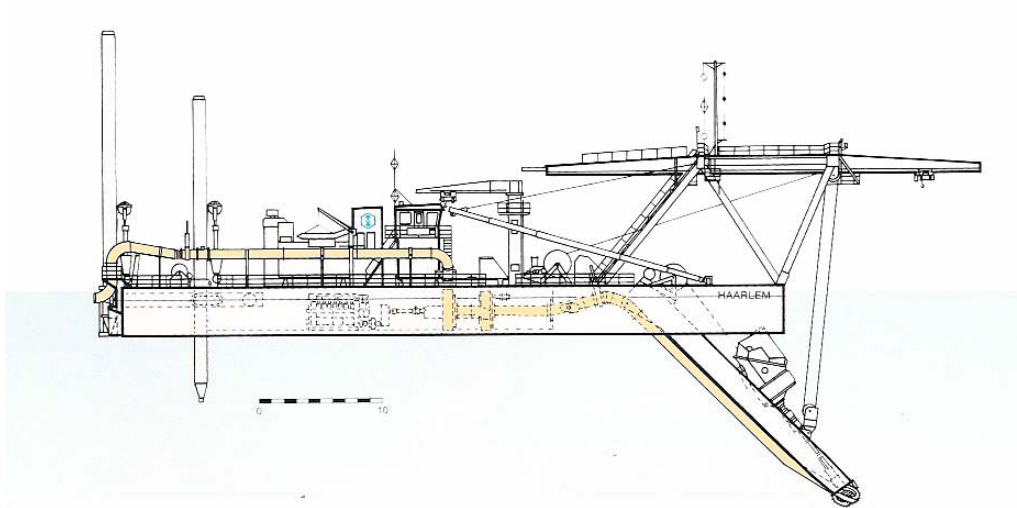

Figure 3. 86 Pipeline layout on a dredger

3.6.10. The winches

The ladder winch

As previously stated, the depth of the cutter head is adjusted by means of the ladder winch. This variable speed winch may be an electric or a hydraulic drive. For heavy ladder constructions, with consequent high forces on the wires, the winch drums are grooved to prevent wire wear. The size of the drums needs a diameter to accommodate the entire wire in the groove. During repairs and transport the ladder is kept in a fixed position (Figure 3.87), often by slings or rods that are directly fastened to the ladder gantry.

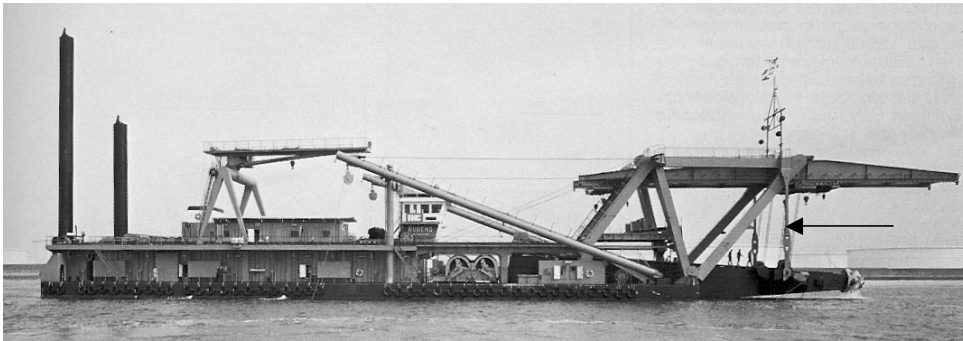

Figure 3. 87

The side winces

The dredging process is controlled with the aid of the side winches. To a large extent the production of a cutter suction dredger is determined by the swing speed. The hauling winch takes care of the feeding of the cutter head, while the paying out winch ensures that wire remains taught. The side winches may also have electric or hydraulic drives.

Modern cutter suction dredgers are often equipped with an automated cutter control system which controls the side winch speed on a number of values such as the cutting power, side winch force (amps), the concentration and the velocity of the mixture.

Older cutter suction dredgers sometimes have side winches that are combined with the ladder winch to form one central winch, thus three drums and one drive. The paying out of the side winch then takes place by freeing it from the drive shaft. Braking is then entirely mechanical. It will be clear that in this case the ladder winch and the side winch cannot be operated independently of each other, which is necessary when dredging slopes.

Other winces

If the dredger is equipped with anchor booms, it needs anchor winches and buoy line winches. Depending on the spud hoist system there may also be spud winches and if the cutter suction dredger must be able to work on a Christmas tree, stern winches and perhaps also a bow winch will be needed. All these winches may be found in either electric or hydraulic form.

3.6.11. Hoisting equipment

On board cutter suction dredgers cranes are necessary to lift heavy parts such as pump houses, impellers and cutter heads. On large dredgers they can often travel over the length of the pontoon.



Figure 3.88 Mobile and fixed cranes

3.6.12. Auxiliary equipment

Cutter suction dredgers require the following auxiliary equipment:

- A flatboat to move the dredger. By this it is understood the towing of the dredger from dredging point to dredging point.
- A work barge with a crane to carry supplies to the dredger. This can also be used to move anchors if there are no anchor booms and to set out or move parts of a floating pipeline. It may also be used to change the cutter head.
- Some cutter suction dredgers even have a special cutter head pontoon. The cutter head rests on this support. The pontoon sails under the raised ladder. (There are also special cutter suction dredgers equipped with cutter manipulators with which the cutter can be removed from the shaft in an easy way and placed on deck, after which a new cutter head can be fitted.)

3.7. The dredging process

When dredging with the cutter suction dredger the three main phases of excavation, transport and disposal can be distinguished too, however in this chapter only the excavation will be considered.

In the process of excavation by cutter suction dredgers an important part is played by the breach-forming characteristics of the soil to be dredged. In good breach-forming soil, which will be defined later, the flow of soil to the underside of the breach is so good that little or no further cutting is required. With soil that does not breach easily, the cutter head must cut the entire face of the bank. This takes more time and thus the production rate will be lower.

In addition to the type of soil and its properties, it appears that the cutter production also depends on a number of the ship's characteristics such as the cutting power, the swing speed and swing force, the spud system, and the position of the anchors during the cutting process. The boundary conditions set by the work, such as the cutting pattern, possible slopes that must be dredged, hydraulic pipeline transport distances, weather conditions and shipping movements also have a big influence on the production.

3.7.1. The spillage

In both breach-forming and non-breach-forming soil, spillage plays an important role. Spillage is defined as the material in the dredging area that comes to rest above the cutting area of the cutter head. In other words spillage is the material that is not taken up by the suction mouth.. (Figure 3. 89)

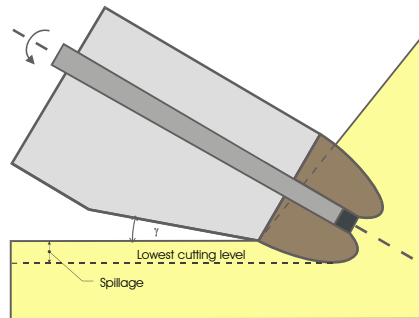

Figure 3. 89

There are two reasons why such material is not recovered by the dredger

1.

The method of working is such that not all the material comes into contact with the cutter head and thus it cannot be taken up. Such a situation arises when the thickness of the material that the cutter head removes with one cut is greater than the diameter of the cutter head. The material which lies above the cutter head falls behind it and thus cannot be taken up. (Figure 3. 90). This phenomenon occurs mainly in cohesive soils such as clay and in rock.

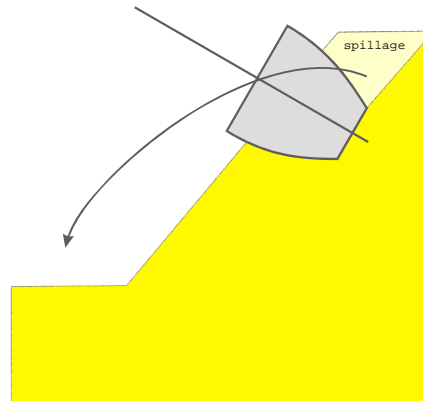

Figure 3. 90

2.

All the dredged ground is not taken up. The reason for this is more complex. Owing to its shape a cutter head has some pumping power. It pumps water in an axial direction to the rear. When the dredge pump is out of action the water taken in by the cutter head leaves the pump close to the ring. As in the case of dredge pumps, the size of the flow that is sucked in by the cutter head is proportional to the revolution speed of the cutter head.

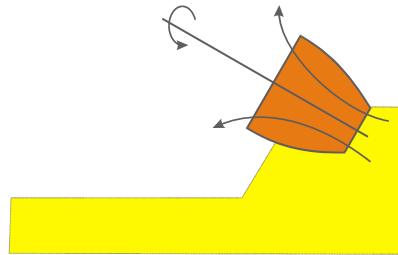

Figure 3. 91

If the dredge pump is also running, the amount of water that leaves the cutter head close to the ring is reduced. In principle it is possible to use such a pump flow rate that no outflow takes place near the ring.

It appears that the percentage of the material cut by the cutter head that is taken up is linearly dependent on the relation::

$$\text{Production} = 1 - \text{Spillage} = \frac{\text{Pump capacity}}{\text{Cutterhead capacity}} = F \cdot \left(\frac{v_z}{\omega \cdot R} \right) = \theta \cdot \frac{Q_{\text{pump}}}{\omega \cdot R_{\text{cutter}}^3}$$

The value of the angle θ depends on the direction of rotation of the cutter head, swing direction and on the material to be dredged. For sand with a $d_{50} < 500\mu$, θ can be taken as 0.4. For soils such as clay and rock the process is much more complicated because the interaction of the separate soil particles with the cutter head play an important role. As stated in chapter 3.2.2.2. θ may be a factor 3 higher in that case. Often in this type of case a constant spillage factor of 0.3 - 0.4 is used.

As mentioned earlier, the spillage also depends on the work method.

When breach-forming soil (Figure 3. 92) that forms an angle of slope α with the horizontal is cut by a cutter head, the spillage depends only on the above mentioned relation of the velocity as long as the underside of the slope passes through the cutter and area I equals area II. The maximum cutter head filling by an unchanging spillage factor is obtained if the cutter head is at right angles to the slope. That is when $\beta + \theta = 90^\circ$, in which θ is the angle that the cutter ladder makes with the horizontal.

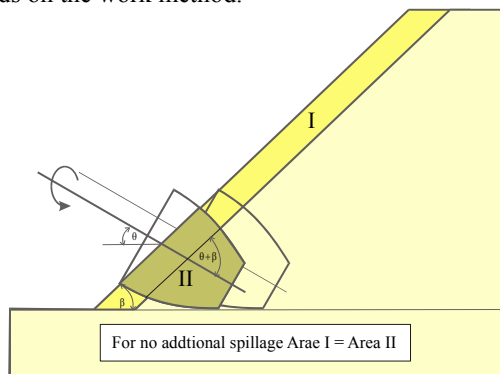

Figure 3. 92

If the underside of the slope runs behind the cutter ring the material will not be cut but will be transported further from the cutter head by the action of the pump. Moreover there is now a good chance that that part have to be shifted by the ladder. See chapter 3.2.2.2 minimum dredging depth.

The further the underside of the ladder comes behind the slope, the greater will be the chance of a dragging ladder. On the other hand the filling of the cutter head is better.

Whether the underside of the slope passes through the cutter ring depends on the breach forming behaviour of the sand, the swing velocity and the size of the step of the cutter head.

3.7.2. The production in breach-forming soils

The breach-forming characteristic of a slope depends on the permeability, thus the grain size and pore volume of the sand layer.

If a suction pipe is quickly lowered vertically into the sand, a pit with almost vertical sides is formed. The dimension of the pit increases with time because the sand grains and fragments of sand slide from the slope and flow to the suction pipe. The bank of the slope moves away from the suction mouth at an almost constant velocity. The velocity is also called the bank velocity V_{wal} . This V_{wal} is roughly 30 * the permeability.

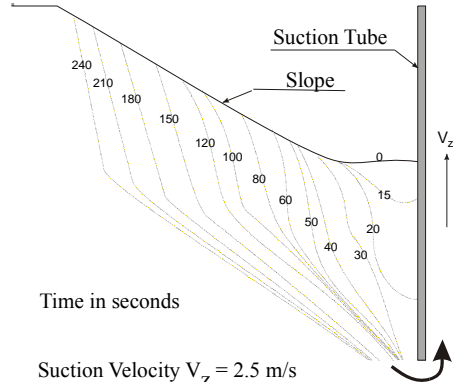

Figure 3.93

In the lecture notes lecture of Wb3413, part “the Breaching Process” the following theoretical value for V_{wal} is derived: $v_{wal} = \frac{k}{\Delta n} \frac{\gamma_k - \gamma_w}{\gamma_w} \frac{1-n}{n} \frac{1}{\tan \phi}$ which leads to the above-mentioned value of $v_{wal} \approx 30k$.

The angle of slope β in front of the suction pipe follows directly from the relation between the bank velocity V_w and the velocity V_h at which the suction pipe moves forward (Figure 3.94.).

$$v_h = v_w \left\{ 1 - \frac{\tan \alpha}{\tan \beta} \right\}$$

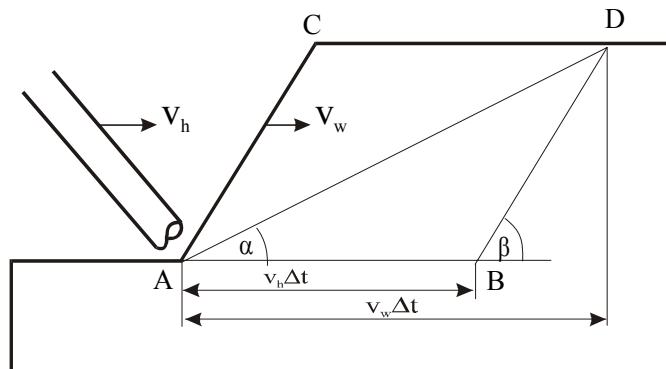

Figure 3.94

(3.12)

From this relation it follows that β is equal to 90° when $V_h = V_w$.

The maximum angle of slope α , the angle at which no more soil runs down to the suction mouth, is for small breach heights the angle of internal friction. In most cases however, and certainly with deep extraction pits, this angle is smaller. With bank heights of 15 m or more, angles of slope of 1:10 to 1:20 occur. The erosion of the sand flowing over the slope causes these.

When dredging good breach-forming soil, with a permeability $1 \cdot 10^{-4}$ en $\alpha = 10^\circ$ at such a depth that the axis of the cutter head makes an angle of 30° with the horizontal, the maximum cutter head filling $\beta = 60^\circ$.

The maximum progress of the dredger is then:

$$v_h = 30 \cdot 10^{-4} \left(1 - \frac{\tan 10^\circ}{\tan 60^\circ} \right) = 27 \cdot 10^{-4} \text{ m/s}$$

The breach production is: $P_b = v_h \cdot B \cdot H$ [m^3/s]

In which:

$$\begin{aligned} B &= \text{width of the cut} && [\text{m}] \\ H &= \text{height of the face} && [\text{m}] \end{aligned}$$

The bank production for a width of 80 m and a face height of 5 m is now:

$$Q_b = 27 \cdot 10^{-4} \cdot 80 \cdot 5 = 1.08 \quad [\text{m}^3/\text{s}]$$

For an average cutter head radius of 1 m, a cutter head speed of 30 revolutions per minute and a suction velocity of 4 m/s in an 800 mm suction pipe, the percentage that can be taken up is:

$$P_f = \theta \cdot \frac{v_z}{\omega \cdot R} = 0.4 \cdot \frac{4}{\pi} = 0.51 \quad [-]$$

The suction production is therefore:

$$Q_s = 0.51 \times 1.08 = 0.55 \quad [\text{m}^3/\text{s}]$$

The spillage is thus 49 % of the face height, that is 2.45 m.

If the revolution of the cutter head is reduced from 30 to 15 revolutions per minute because no cutting process develops in breach forming soil, then :

$$P_f = 0.4 \cdot \frac{4}{0.5 \cdot \pi} = 1.02 \quad [\text{m}^3/\text{s}]$$

Because there is always some loss, for example due to the variation in the permeability of the sand layer, Q_s is given an upper threshold $P_f = 0.9$

The suction production is then:

$$Q_s = 0.9 \times 1.08 = 0.97 \quad [\text{m}^3/\text{s}]$$

The spillage is now only 45 cm.

In breach-forming soil the ladder is almost at maximum depth and only swings from port to starboard and back.

If a specified depth must be dredged it is always necessary to make a clean-up sweep: a final swing, which removes all irregularities.

The question that now arises is how quickly must the cutter head swing in order to remove this material..

If the area of the cutter contour is assumed to be $A_c = 3 \text{ m}^2$, the cutter head must move at a swing velocity of:

$$v_t = \frac{Q_b}{A_c} = \frac{1.08}{3} = 0.36 \text{ m/s} = 21.6 \text{ m/min}$$

Whether or not the side winches are able to deliver this velocity in one way or another must be ascertained. (see chapter 3.2.2.3)

The area A_c that the cutter head cuts while swinging across the face also determines the step size that the dredger must make in the corners. After all the face production must be equal to the cutting production, thus:

$$A_c \cdot v_t = H \cdot S \cdot v_t \Rightarrow S = \frac{A_c}{H} \quad [\text{m/s}]$$

v_t = translation velocity of the cutter in [m/s]

The average production reached during a full dredging cycle, that is the time between two movements of the spuds, is in fact lower. This is because stepping, moving the spuds and, if necessary, raising the ladder, all take time. These factors are entirely dependent on the spud system and the time needed to perform the various procedures.

3.7.3. The production by non-breach forming soils

If the soil forms an inadequate breach or does not breach at all, as is the case with cohesive soils such as clay and rock, and to a lesser degree fine sand, the cutter head must do what it is designed for, that is cut the soil loose.

Depending on the type of soil, the spud system, the suction depth and the insight of the dredge master, the breach may be cut in various ways. Figure 3. 95 gives an example for a cutter suction dredger with fixed spuds.

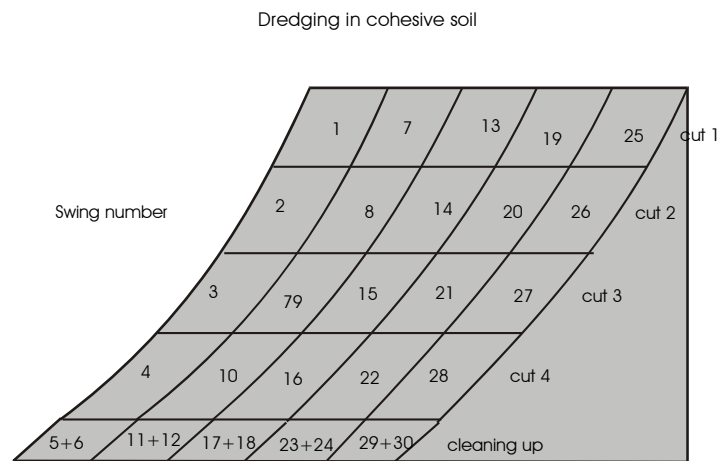

Figure 3. 95

If the dredger has a spud carriage the variety of ways in which the breach can be cut is even greater (Figure 3.96). This pattern is used when the cut is to be made to the desired depth in a single cut. The numbering gives the order of cutting.

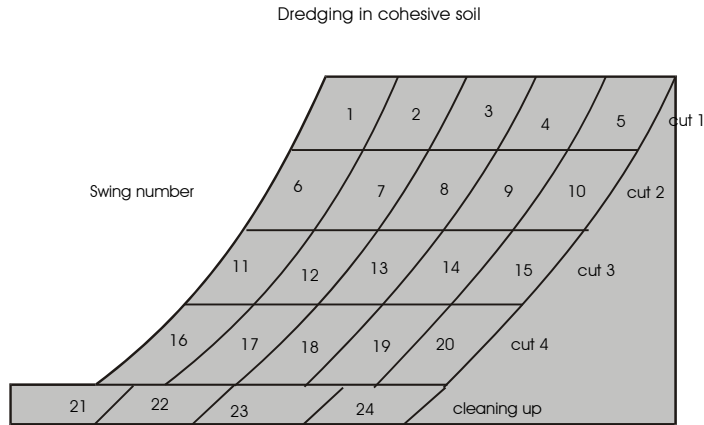

Figure 3.96

If the breach rises above the water level, in order to prevent a spillage problem. The pattern shown in Figure 3.97 or Figure 3.98 must be used.

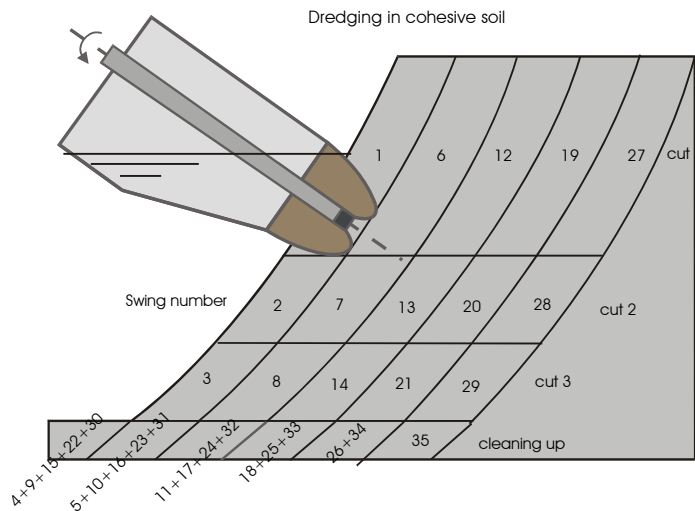

Figure 3.97

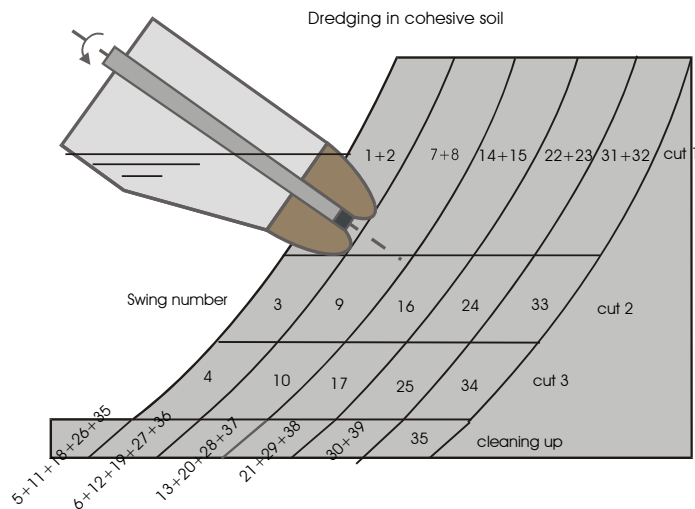

Figure 3.98

3.7.4. Specific energy

The number of layers over which the breach is cut, the step size and the swing velocity are closely related to the specific energy that is required to cut the soil. The energy consumption per unit of production is called the specific energy and is thus, by definition, the energy that is needed to cut loose one m^3 of soil. Although it is often thought that the specific energy is independent of the cutting process, it is certainly not, since the finer the material that must be cut, the greater the energy consumption.

The cutting method also exerts a big influence. When cutting rock, the specific energy increases strongly as the teeth are worn away. Furthermore the influences of the radius and the revolutions of the cutter head are limited, so no account can be taken of the possible dependence of cutting force on the velocity or of the permissible torque.

To obtain some insight into this subject, the specific energy is calculated from a general cutting theory or a straight cutting edge on a rotating cutter head.

With a linear movement the cutting force of a straight cutting edge can be characterised by the following power equation:

$$F_c = c \times d^\alpha \times v_t^\beta \times W \quad [\text{N}]$$

in which:

c	=	a constant that is dependent on the soil type and on the boundary conditions such as water depth, cutting edge angle, cutting edge height, etc	
d	=	the cutting depth or slice thickness	[m]
V_t	=	the cutting velocity	[m/s]
W	=	the width of the cutting edge	[m]

The production of a straight cutting edge is:

$$Q = d \cdot V_t \cdot W \quad [\text{m}^3/\text{s}]$$

Therefore the specific energy is:

$$E_s = \frac{F_c \times v_t}{Q} = \frac{c \times d^\alpha \times v_t^\beta \times W \times v_t}{d \times v_t \times W} = c \times d^{\alpha-1} \times v_t^\beta \quad [\text{J}/\text{m}^3]$$

From this it follows that the specific energy is only constant if the cutting process is entirely linear, thus when:

$$F_c = c \times d \times v_t \times W$$

If this theory is applied to cutting with a cutter the chip thickness is:

$$d = \left(\frac{2\pi \times v_t}{\omega \times z} \right) \times \sin\theta$$

$$d = p \times \sin\theta$$

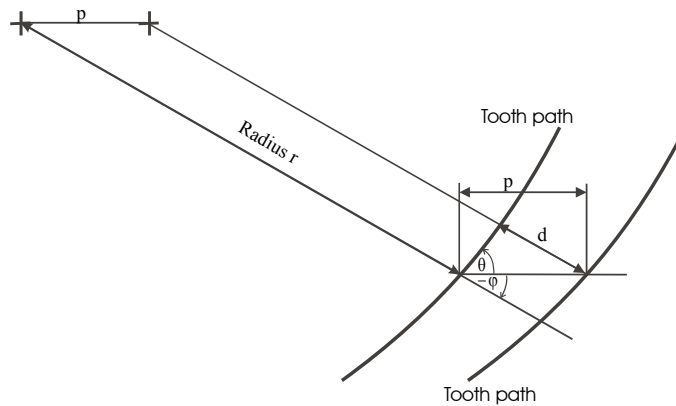

Figure 3. 99

ω = the angular velocity of the cutter head

[rad/s]

z = the number of cutter arms

[-]

v_t = the swing velocity [m/s]
 θ = the angle between the cutter radius and the tooth path [radian]

The maximum chip thickness is: $d_{\max} = \left(\frac{2\pi \cdot v_t}{\omega \cdot z} \right)$

Because the peripheral velocity of the cutter is equal to $\omega \cdot R$, the cutting force of a cutter

$$\text{is: } F_c = c \left[\left(\frac{2\pi \times v_t}{\omega \times z} \right) \times \sin\theta \right]^\alpha (\omega \times R)^\beta \times L$$

$$L \text{ is proportional to the step size } S \text{ thus: } F_c = c \left[\left(\frac{2\pi \times v_t}{\omega \times z} \right) \times \sin\theta \right]^\alpha (\omega \times R)^\beta \times S$$

Moreover the cutting power is equal to: $P_c = F_c \times v_t = F_c \times \omega \times R$

$$P_c = c \left[\left(\frac{2\pi \times v_t}{\omega \times z} \right) \times \sin\theta \right]^\alpha (\omega \times R)^{\beta+1} \times S$$

With increasing step size the average radius of the cutter head increases; thus $R = f(S) = S^\delta$.

$$\text{From this the cutting force can be reduced to: } P_c = c \left[\left(\frac{2\pi \times v_t}{\omega \times z} \right) \times \sin\theta \right]^\alpha (\omega \times S^\delta)^{\beta+1} \times S$$

The cutting production is: $Q_c = S \times v_t \times D$

and thus the specific power:

$$E_s = \frac{c \left[\left(\frac{2\pi \times v_t}{\omega \times z} \right) \times \sin\theta \right]^\alpha (\omega \times S^\delta)^{\beta+1} \times S}{S \times v_t \times D} = \frac{c \left[\left(\frac{2\pi \times v_t}{\omega \times z} \right) \times \sin\theta \right]^\alpha (\omega \times S^\delta)^{\beta+1}}{v_t \times D}$$

From this equation it follows directly that the specific cutting power is constant only under very exceptional conditions. These conditions are:

- A cylindrical cutter head $\delta = 0$
- The cutting force must increase linearly with increasing chip thickness.
- This gives $\frac{v_t^\alpha}{v_t} = v_t^{\alpha-1}$ is constant
- The average chip thickness must be linear with the layer thickness. Thus $\frac{[\sin\theta]^\alpha}{D}$ is constant
- The cutting force must be independent if the constant $\beta = 0$

Then:

$$E_s = c \cdot \frac{R}{z}$$

From this it follows that the specific cutting energy is always dependent on the type of cutter head.

Because there are often big variations in the types and strength of the soil and many factors that cannot be determined in advance play a part in the cutting process, the specific energy appears to be a good parameter for estimating the production of cutter suction dredgers.

3.7.5. The cutting production

The specific energy required for a particular type of soil can be estimated with the aid of existing cutting theories or from production estimates from previous work with the same type of soil.

If the specific energy E_{sp} , is known, it follows from the definition of the cutting process:

$$P_c = \frac{w \cdot N_c}{E_s}$$

in which N_c is the cutter power.

The value w , a work coefficient, gives an indication of the average maximum percentage of the installed cutting power that can be used. This value is dependent, not only on the type of soil (relation between peak forces and average forces), but also on the man-machine relation. The dredge master and the automated cutter control regulate the cutting speed on the basis of the amperage (torque) of the cutter head engine.

Types of soil the hardness or strength of which vary greatly from place to place will give a torque or amperage signal that varies greatly over time in which N_c is the cutter power (Figure 3. 100.)

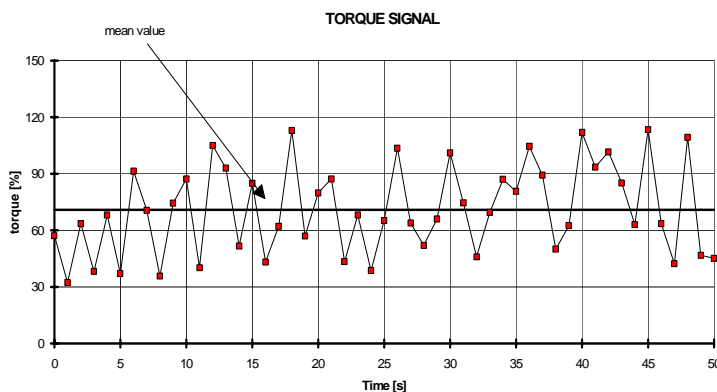

Figure 3. 100.

This may quickly lead to overloading of the cutter head engine, with the result that, for example, for the torque-revolution characteristic shown below, the cutter head will stall at a torque of 150% (Figure 3.101)

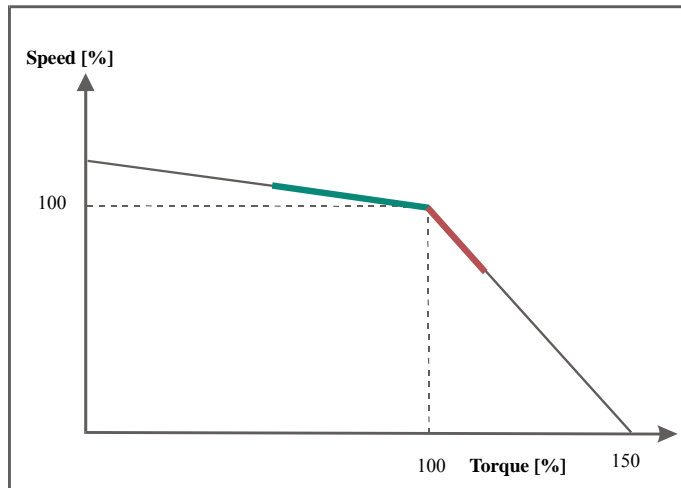

Figure 3. 101 Torque speed Characteristics of an electrical drive

If this occurs frequently the dredge master will reduce the swing speed of the dredger to ensure that the peak loads do not cause the cutter to cease turning.

It will be clear that the type of drive plays a big part in this. An electric drive can take up the variation in torque better than a hydraulic drive. (See chapter 3.4.2.)

The skill of the dredge master also plays a part. Dependence on his skill can be reduced to some extent by the use of an automated cutter control. This regulates the swing velocity, for example in relation to the torque of the cutter head. In many cases such an automated control system can react more quickly than the dredge master can, certainly at times when his watch is almost over.

It will also be clear that only rough estimates can be given for such a factor as the work coefficient.

For rock : $w = 0.5 - 0.65$

For sand : $w = 0.65 - 0.8$

For clay : $w = 0.8 - 0.9$

An automated cutter control increases these values by 10% to 20%.

With the information given above, the cutting process can be found and also the warping speed of the cutter head. Because:

$$Q_c = S \times v_t \times D \quad [m^3/s]$$

With

P_c = cutting production $[m^3/s]$

D = layer thickness $[m]$

S = step size $[m]$

V_h = swing velocity $[m/s]$

3.7.6. The spillage

The face is cut away layer by layer, the spillage of one layer will be entirely or partly cleared away during the cutting of the following layers.

For this reason the cutting of layers over the length of the spud carriage (Figure 3. 102 left) is preferable to the pattern shown in Figure 3. 102 right

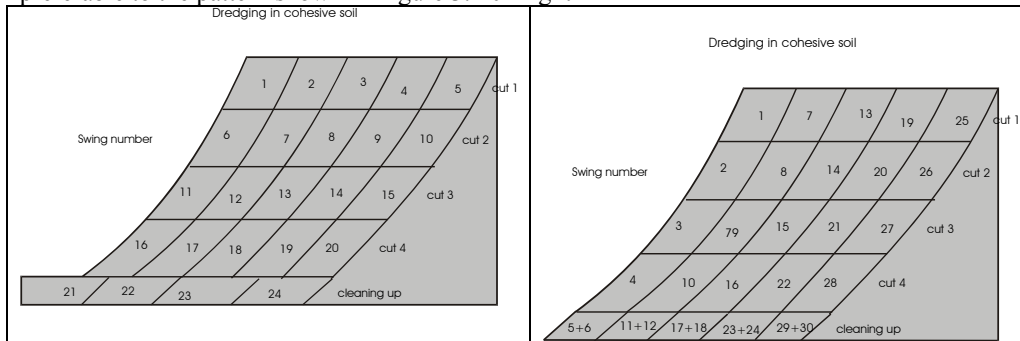

Figure 3. 102

In this case the spillage can be calculated as follows:

Assume that the spillage is M % of the cut surface. (M can be determined in the same way as in breach forming soil.). If the thickness of the layer and the step do not greatly exceed the dimensions of the cutter head, the spillage is M % of the layer thickness. Thus:

- for layer 1: $Z_1 = M \cdot D$ $D = \text{layer thickness}$
- for layer 2: $Z_2 = M(D + M \cdot D)_1 = (M + M^2)D$
- for layer k: $Z_k = (M + M^2 + M^3 + \dots + M^k)D$

After simplification it follows that:

$$Z_k = M \cdot D \frac{1 - M^k}{1 - M} = \frac{M(1 - M^k)}{k(1 - M)} H$$

The part taken up is thus:

$$S_k = H - Z_k = H \left(1 - \frac{M(1 - M^k)}{k(1 - M)} \right)$$

Clearly, when the thickness of the layer or the size of the step exceeds the dimensions of the cutter head the part of the material that has no chance of entering the cutter head must immediately be considered as spillage. Figure 3. 103 shows a breach, which projects above water.

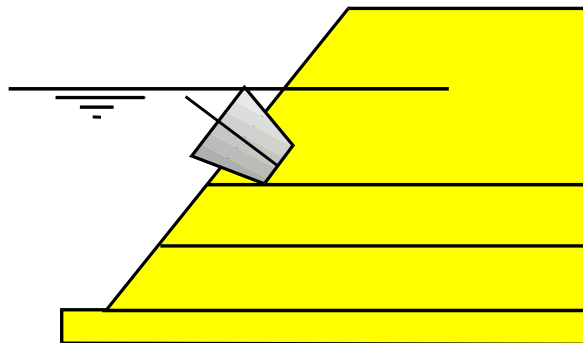

Figure 3. 103

Because the suction mouth must remain sufficiently under water to prevent the taking in of air, the dredge master must make the first cut thicker than the diameter of the cutter head.

The direction in which the bank is stripped now affects the spillage, although not in the cut, which is being dredged, but in the cut that has already been dredged. If the first cut has been made with a reverse turning cutter working towards the already dredged cut, because of the failure to raise the necessary reaction force, it is possible that at the end of the cut, some of the material from this new cut is pushed into the already dredged area.

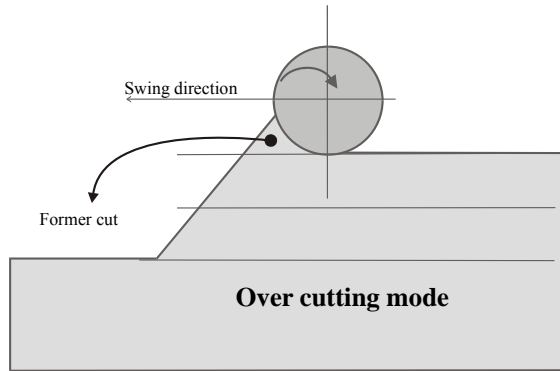

Figure 3. 104

The result is that a ridge of soil is formed on the boundary between the cuts. In such a case it is better to make the uppermost cut in the same direction as the rotation of the cutter head. If the spillage is known the average dredging production over one spud cycles is:

$$Q_s = \frac{S_k \cdot W \cdot L}{t_s + \sum t_a} \quad [m^3/s]$$

in which:

- S_k = the thickness of the layer which has been taken up [m]
- W = the width of the cut [m]
- L = effective advance of the spud carriage [m]
- t_s = net cutting time during a spud cycle [s]
- $\sum t_a$ = the sum of the times during the spud cycle when no cutting occurs, such as ladder raising, stepping, spud moving ,etc. [s]

In non-breach forming soil, if a specified depth has to be delivered a clean-up swing must also be made. The production of this swing is calculated separately. The cutting energy that is required in this layer can only be determined from the part that has not been cut. It is therefore possible that because of a thin layer, the clean-up production is high.

3.8. Enclosures

3.8.1. The relation between swing speed and side winch speed.

The swing speed of the cutter head must not be confused with the side wire speed. The latter is the speed with which the side wire is hauled in and which controls the swing velocity. Although there is a clear relation between these two velocities, they are certainly not equal. The position of the anchors in relation to the cut plays an important part in this. By the correct positioning of the anchors it is possible to reach a high swing velocity with a small side winch velocity.

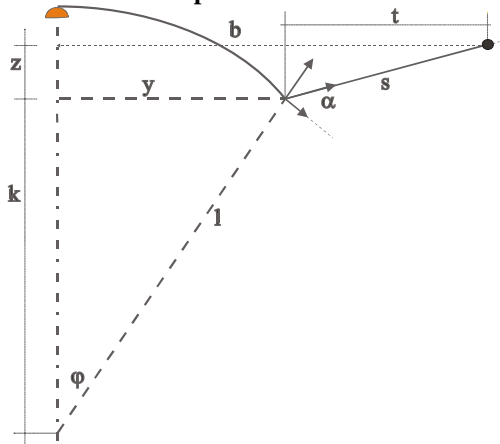

Figure 3. 105

In Figure 3.105 the distance between the work spud and the sheaves of the side winch on the ladder is equal to L and the distance between the sheaves and the anchor is equal to S . If the angle between the centreline of the cut and the line linking the spud-side winch sheaves is equal to θ , then:

$$x = l \cdot \cos \varphi$$

$$y = l \cdot \sin \varphi$$

$$z = k - x = k - l \cdot \cos \varphi$$

$$t = b - y = b - l \cdot \sin \varphi$$

$$s = \sqrt{z^2 + t^2} = \sqrt{(k - l \cdot \cos \varphi)^2 + (b - l \cdot \sin \varphi)^2}$$

$$\frac{ds}{dt} = \frac{ds}{d\varphi} \frac{d\varphi}{dt} = \frac{2 \cdot (k - l \cdot \cos \varphi) \cdot (-l \cdot \sin \varphi) \cdot \dot{\varphi} + (b - l \cdot \sin \varphi) \cdot (-l \cdot \cos \varphi) \cdot \dot{\varphi}}{2 \cdot \sqrt{(k - l \cdot \cos \varphi)^2 + (b - l \cdot \sin \varphi)^2}}$$

Since $l \cdot \dot{\varphi}$ is the swing velocity, the previous equation can also be written:

$$\frac{ds}{dt} = l \cdot \dot{\varphi} \frac{k \cdot \sin \varphi - l \cdot \sin \varphi \cdot \cos \varphi - b \cdot \cos \varphi + l \cdot \sin \varphi \cdot \cos \varphi}{\sqrt{k^2 - 2 \cdot k \cdot l \cdot \cos \varphi + l^2 \cdot \cos^2 \varphi + b^2 - 2 \cdot b \cdot l \cdot \sin \varphi + l^2 \cdot \sin^2 \varphi}}$$

of

$$\frac{ds}{dt} = \frac{\frac{k}{l} \cdot \sin \varphi - \frac{b}{l} \cdot \cos \varphi}{\sqrt{\left(\frac{k}{l} - \cos \varphi\right)^2 + \left(\frac{b}{l} - \sin \varphi\right)^2}} \cdot l \dot{\varphi}$$

Since the side winch force do not act on the ladder at the same distance from the spud as the cutter head, the swingspeed have to be corrected according: $\frac{v_s}{v_c} = \frac{l}{l_c}$

3.8.2. The side winch force and power

The swing force F_h takes effect at right angles to the centreline of the dredger, thus in the direction of the movement of the cutter head. The chance that the anchor is positioned in exactly the same direction as this track of the cutter head is valid for only one point. If the angle made by the tangent at one point of the track of the cutter head with the line joining this point to the anchor position is α , the required side winch power is $F_z = F_h / \cos(\alpha)$.

$\cos(\alpha)$ can also be expressed in the units given in.

$$\cos \alpha = \cos \left[\frac{\pi}{2} + \varphi - \arctan \left\{ \frac{\frac{b}{l} - \sin \varphi}{\frac{k}{l} - \cos \varphi} \right\} \right] \quad (3.45)$$

The side winch force is thus:

$$F_z = \frac{F_h}{\cos \alpha} = \frac{F_h \cdot R_c}{M_c \cos \alpha} = \frac{F_h \cdot R_c}{M_c \cos \left[\frac{\pi}{2} + \varphi - \arctan \left\{ \frac{\frac{b}{l} - \sin \varphi}{\frac{k}{l} - \cos \varphi} \right\} \right]} \quad (3.46)$$

If the diameter of the side winch drum is equal to D_w , the required side winch torque is:

$$M_w = \frac{F_h \frac{D_w}{2}}{\cos \alpha} = \frac{F_h \cdot R_c \frac{D_w}{2}}{M_c \cos \alpha} = \frac{F_h \cdot R_c \frac{D_w}{2}}{M_c \cos \left[\frac{\pi}{2} + \varphi - \arctan \left\{ \frac{\frac{b}{l} - \sin \varphi}{\frac{k}{l} - \cos \varphi} \right\} \right]}$$

Both the side winch velocity and the side winch torque are now known as functions of the position of the anchors and the position of the cutter head in the cut. Neither the necessary side winch velocity, nor the necessary torque may exceed the maximum value of the side winch characteristic. If this does happen, the side winch velocity must be reduced until this condition is met.

Because during the progress of the dredger the positions of the anchors in relation to the track of the cutter head must be continually changed, if the side winch velocity or the side winch force is the limiting factor for the dredging process, the dredge master must continuously adjust the side winch velocity until the point is reached where it seems wiser to move the anchors.

From the above it will be clear that the further away the anchors are positioned from the ship, the longer the force will be effective, thus the anchors will have to be moved less often. On the other hand the longer the side wires, the weaker the system will be. This is a disadvantage when dredging hard soil such as rock.

From the relation between the swing velocity v_h or the angular velocity φ , together with required side winch electric current, dredge master can see whether or not the anchor is holding or dragging.

3.8.3. The shape and cutting geometry of cutter heads

Because the cutting process plays an important role in excavation, this section will give more detailed consideration to the shape and cutting geometry of cutter heads.

Definitions:

The base plane is the plane that passes through the underside of the cutter ring.

The cutting point P may be a point on a cutting edge of a plain edge, the cutting point of a serrated edge or the edge or point of a tooth. The position of the cutting point determined by the cylinder coordinates R_p , H_p , and ϕ_p .

Here:

R_p = the radius from the cutting point to the cutter axis.

H_p = the distance between the cutting point and the base plane.

ϕ_p = the angle between the projection of the cutting point onto the base plane and the cutting point ($R_p, 0, 0$)

The cutting edge of a cutter blade is the smooth curve passing through the cutting points.

The contour or outline of the cutter head is the section made by the cutting edge (the contour plane) through a plane perpendicular to the axis of the cutter head.

The contour tangent touches point P on the contour.

The contour angle κ is defined as the angle between the line in the contour plane passing through P at right angles to the contour tangent and the line through P parallel to the base plane.

The cutting plane is at right angles to the contour plane and the contour tangent..

In the dredging world both Florida and Esco cutters are used. The positions of the tooth points of both systems are determined by using cylinder coordinates.

The direction of the tooth axis given by Esco differs from that given by Florida.

Tooth axis direction according to ESCO

ESCO gives the direction of the tooth axis in two ways:

1. By giving the tooth point and the tooth base of the tooth axis in cylinder coordinates.
- 2e. By giving the tooth point and two angles of the tooth axis.

These angles are defined as follows:

- The pitch out angle θ . This is the angle between the tooth axis projection in the plane parallel to the base plane and the tangent on the circle passing through the tooth point projection.
- The pitch up angle ϕ this is the angle between the tooth axis and its projection in the plane parallel to the base plane..

Thus in Figure 3.77.:

$$\theta = \arctan\left(\frac{P'B'}{BB'}\right)$$

en

$$\phi = \arctan\left(\frac{PP'}{P'B'}\right)$$

In addition ESCO give the roll angle ρ (rho) of a tooth. This is the position of a tooth in relation to the tooth axis.

The roll angle \square is the angle between the edge of a chisel (flared or chisel leading edge) and the line parallel to the cutter axis as seen along the tooth axis. This angle is equal to the centreline of the locking pin and the line parallel to the base plane seen along the tooth axis.

Tooth axis direction according to FLORIDA.

FLORIDA gives the tooth axis by the giving coordinates of the tooth point with two angles.

FLORIDA defines these angles as follows:

- The tooth axis angle α (tooth angle). This is the angle between the tooth axis and the tangent on the circle passing through the tooth pint. This is the tangent to the line of the movement during rotation.

- The contour angle κ_t (Kappa=Profile angle) of the tooth. This is the angle between the tooth axis projection in the contour plane and the line parallel to the base plane (P'B').
- FLORIDA has a fixed roll angle ρ (rho) because the cutting edge or blade edge of the tooth always lies in the contour plane. This makes the roll angle a function of the tooth axis angle α and the contour angle κ_t

$$\rho_{\text{Florida}} = \arctan[\tan \kappa_t \cdot \cos \alpha]$$

When working, in most cases a piece of auxiliary equipment, the so-called ALFE is used in order to ensure that adapters are correctly positioned on the cutter head arm when these have to be replaced owing to breakage or loss (Figure 3. 106.). The plane of the ALFE is thus a contour plane.

In that case the FLORIDA instruction is more simple than the ESCO. With ESCO cutter heads the angles must be recalculated to the FLORIDA instruction.

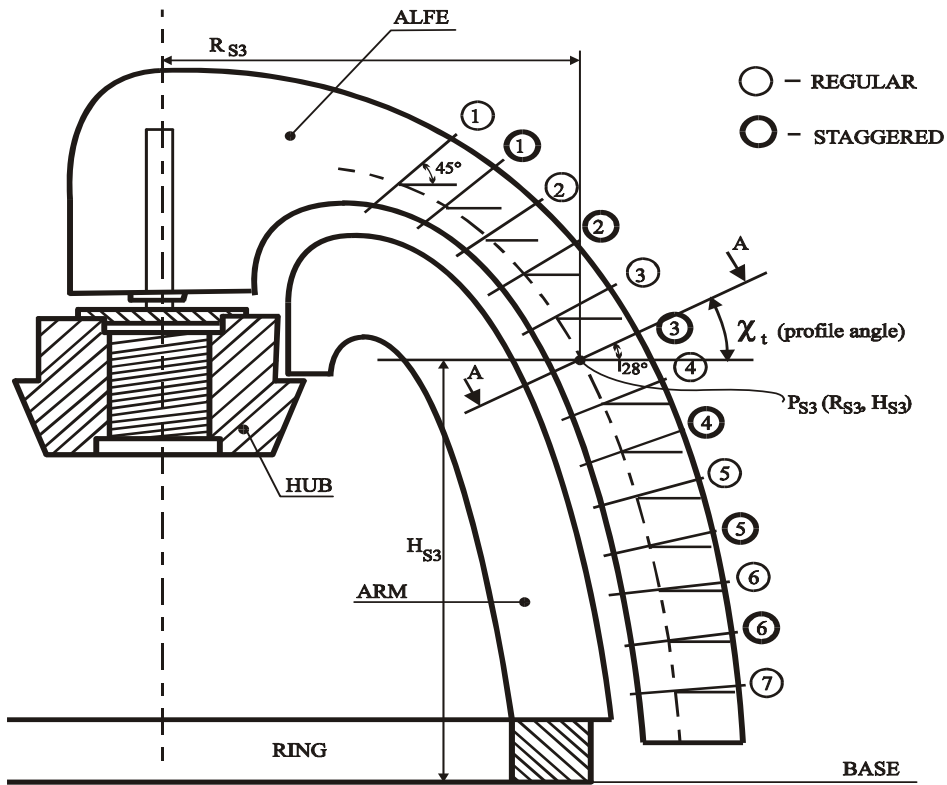

VIEW A-A

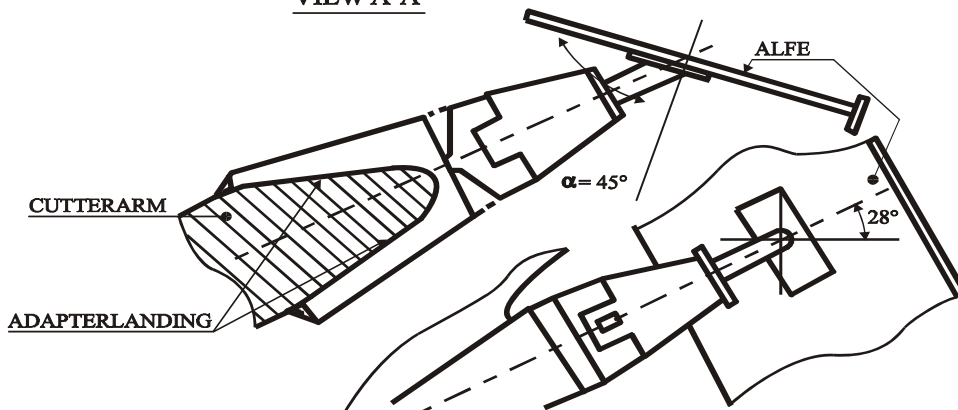

Figure 3. 106

Tooth axis angle α

$$\alpha = \arccos(\cos \theta \cdot \cos \phi)$$

Contour angle κ_t

$$\kappa_t = \arctan\left(\frac{\tan \phi}{\sin \theta}\right)$$

Roll angle

$$\rho_{Florida} = \rho_{Esco} - \rho_{mal}$$

Here ρ_{mal} is the angle over which the adapter must be turned on its axis to get the cutting edge in the contour plane, thus against the ALFE. ρ_{mal} may be positive or negative.

3.8.4. Cutting by teeth or chisels

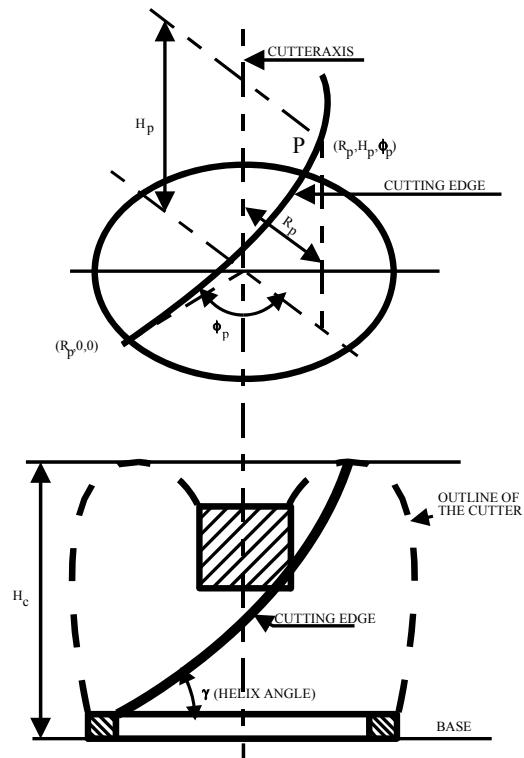

Figure 3.107

For the definitions of the various angles see Figure 3.107.

- Cutting edge/rake angle
- Tooth axis angle
- Clearance angle
- Wedge angle

In addition to a clearance angle on the rear of a chisel there are also side clearance angles.

3.8.5. Conditions for cutting clearance

The front and rear edges of the arms of cutter heads, edges, teeth and chisels follow different tracks during the cutting process (Figure 3.108). The most unfavourable point for the cutting clearance is the point where the velocity vector s of both the front and rear edges are parallel. In that case there is a maximum and minimum distance between the two paths. This happens when the velocity component in the X-direction is $v_x=0$.

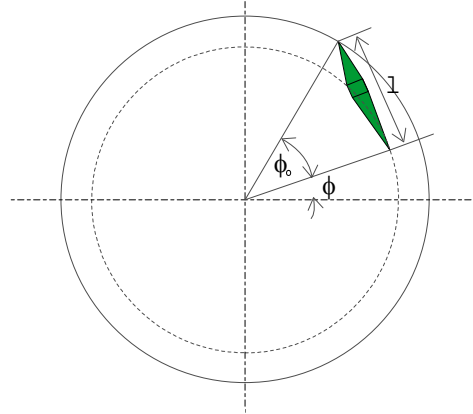

Figure 3. 108

The path of a point on a cutter head can be described by the two following equations in parameter form (Figure 3.81.):

$$x_p = v_h \cdot t + R_p \cdot \cos \omega t$$

$$y_t = R_p \cdot \sin \omega t$$

$$\varphi = \omega \cdot t$$

Here:

X_p, Y_p = the coordinates of the point P with regard to the cutter head axis.

v_h = the swing velocity of the cutter head

ω = the angular velocity of the cutter head

R_p = the radius of the cutter head

t = the the time of passagede

The direction of the velocity is the tangent to the path:

$$\frac{dy}{dx} = \frac{dy}{dt} \cdot \frac{dt}{dx} = \frac{R_p \cdot \omega \cdot \cos \omega t}{v_h - R_p \cdot \omega \cdot \sin \omega t}$$

The velocity in the x-direction is zero when the derivative is infinite, thus as:

$$v_h - R_p \cdot \omega \cdot \sin \omega t = 0$$

Further:

$$y = R_p \cdot \sin \omega t$$

so that:

$$v_h - y \cdot \omega = 0$$

$$\therefore y = \frac{v_h}{\omega}$$

and the associated angle φ :

$$\varphi_p = \arcsin \frac{V_h}{\omega \cdot R_p}$$

Now when:

l = distance between the front of the tooth and the rear of the arm

R_v = the radius of the tooth point and R_a , the radius of the rear of the arm .

then:

$$\varphi_v = \arcsin \frac{V_h}{\omega \cdot R_v}$$

and

$$\varphi_a = \arcsin \frac{V_h}{\omega \cdot R_a}$$

Furthermore if l is the distance between the front of the tooth and the rear of the arm, it follows from Figure 3.80 with $\varphi=0$ that the angle between the two points mentioned is equal to:

$$l = \sqrt{(R_v \cdot \cos \varphi_0 - R_a)^2 + (R_v \cdot \sin \varphi_0)^2}$$

$$l^2 = (R_v \cdot \cos \varphi_0 - R_a)^2 + (R_v \cdot \sin \varphi_0)^2$$

$$l^2 = R_v^2 + R_a^2 - 2 \cdot R_v \cdot R_a \cdot \cos \varphi_0$$

$$\therefore \varphi_0 = \arccos \left(\frac{R_v^2 + R_a^2 - l^2}{2 \cdot R_v \cdot R_a} \right)$$

The tooth and arm now run clear if the horizontal distance between the paths at the distance y is greater than the distance the cutter head moves as a result of the following the swing velocity round the $\varphi_0 + \varphi_a - \varphi_v$.

Thus when

$$R_v \cdot \cos \varphi_v - R_a \cdot \cos \varphi_a \geq (\varphi_0 + \varphi_a - \varphi_v) \frac{V_h}{\omega}$$

Example:

$R_v = 1.50$ m, $R_a = 1.45$ m, $l = 0.7$ m $v_h = 0.3$ m/s en

$\omega = \pi$ (n=30 t/min)

then:

$$R_v \cdot \cos \varphi_v = 1.497$$

$$R_a \cdot \cos \varphi_a = 1.447$$

$$\varphi_v = 0.064$$

$$\varphi_a = 0.066$$

$$\varphi_0 = 0.478$$

$$y = 0.095$$

The maximum side winch velocity may then be:

$$v_h \leq \frac{(R_v \cdot \cos \varphi_v - R_a \cdot \cos \varphi_a) \cdot \omega}{\varphi_0 + \varphi_a - \varphi_v}$$

thus $v_h \leq 0.33$ m/s

It will be clear that when designing cutter heads this exercise must be carried out for a number of points on the cutter head, since cutter arm length and radius are a function of the height of the cutter head, measured from the ring.

This also determines the maximum thickness of the cut. When the rear of the arm touches the path of the front of the tooth, the maximum cut thickness is equal to:

$$d_{\max} = \frac{60 \cdot (v_h)_{\max}}{n \cdot z}$$

in which z is the number of arms.

From the example it thus follows that:

$$d_{\max} = \frac{60 \cdot (v_h)_{\max}}{n \cdot z} = \frac{60 \cdot 0.33}{30 \cdot 6} = 0.11 \text{ m}$$

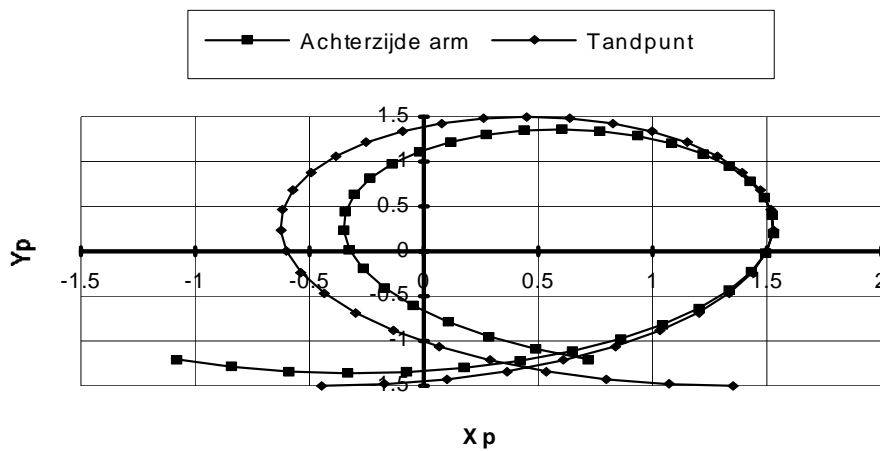

Figure 3. 109

Finally the same example, but now with $n=10$ t/m and $R_a=1.36$ m. $d_{\max}=0.30$ m and $v_{\max}=0.30$ m/s.

The path of the two points is shown in Figure 3. 109..

If parts of the tooth or arm project through the line passing between the tooth point and the rear of the arm, it is necessary to carry out a check for more points.

The effect of warping on the clearance angles

The direction of the movement of the tooth point is (see Figure 3. 110):

$$\left(\frac{dy}{dx}\right)_{\text{baan}} = \frac{R_p \cdot \omega \cdot \cos \omega t}{v_h - R_p \cdot \omega \cdot \sin \omega t} = \frac{R_p \cdot \omega \cdot \cos \varphi}{v_h - R_p \cdot \omega \cdot \sin \varphi}$$

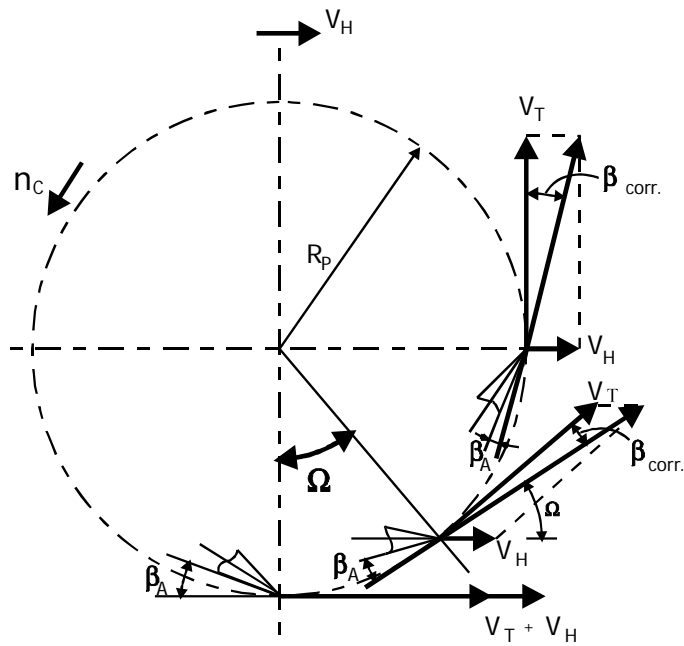

Figure 3. 110

The rear plane of the tooth makes an angle β_A with the circumference of the cutter head, thus with the tangent on the circle:

$$\left(\frac{dy}{dx}\right)_{\text{circle}} = \frac{R_p \cdot \omega \cdot \cos \omega t}{-R_p \cdot \omega \cdot \sin \omega t} = \frac{R_p \cdot \omega \cdot \cos \varphi}{-R_p \cdot \omega \cdot \sin \varphi} = \frac{-1}{\tan \varphi}$$

The clearance angle between the path of the tooth and the back of the tooth thus varies with the rotation.

The difference between the two tangents is the varying clearance angle:

$$\beta_{\text{corr}} = \arctan\left(\frac{R_p \cdot \omega \cdot \cos \varphi}{v_h - \omega \cdot \sin \varphi}\right) - \arctan\left(\frac{-1}{\tan \varphi}\right) = \arctan\left(\frac{R_p \cdot \omega \cdot \cos \varphi}{v_h - \omega \cdot \sin \varphi}\right) - \frac{\pi}{2} - \varphi$$

For $R_p = 1.0\text{m}$, $\omega = 0$, $\varphi = 0$ and $v_h = 0.3 \text{ m/s}$ it follows that:

$$\beta_{\text{corr}} = \arctan\left(\frac{\pi}{0.3-0}\right) - \frac{\pi}{2} = -0.0095 \text{ rad} = -5^\circ.27'$$

In other words, the cutting angle is $5^\circ 27'$ smaller.

3.9. References

1. calculation of the cutting forces when cutting in fully saturated sand, S.A. Miedema, Thesis TU-Delft, 1987 (in Dutch)
2. Coastal and Deep Ocean Dredging, John B. Herbich, Gulf Publishing Company, Houston, Texas, U.S.A., 1975
3. Dredging and Dredging Equipment, R.J. de Heer and Rochmanhadi, Parts 1 and 2, IHE, Delft, 1989
4. Dredging technology, lecture notes, G.L.M. van der Schrieck, TU-Delft, Civiele techniek, 1996 (in Dutch)
5. Concept, design and construction of the World's first self elevating offshore heavy cutter suction dredger: "Al Wassl Bay", D.A. Gaasterland, Proceedings 3e International Symposium on Dredging Technology, BHRA 198?
6. Nassbaggetechnik, A. Welte, Institut für Maschinenwesen in Baubetrieb, Universität Fridericiana, Karlsruhe, 1993.
7. Proceedings of the CEDA Dredging Days, Europort 1980, CEDA, 1980
8. Technical aspects of large cutter suction dredgers, P.J. Koert, IHC Holland
9. Dredgers of the World, 3rd edition, Oilfield Publications Ltd (OPL). England, 2001
10. Various articles from Port & Dredging from IHC Holland

ARTICLE	P & D no
Spudsystemen van cutterzuigers	108
Demonteerbare cutterzuiger/baggerwielzuiger SCORPIO	108
IHC Beaver cutterzuigers	109
Cutterzuiger NOORDZEE	118
Automatisering van cutterzuigers	119
Zelfvarende cutterzuiger van 27000 PK	119
LEONARDO DA VINCI: een nieuw record	124
Nieuwe serie IHC Beaver cutterzuigers	126
The IHC Beaver container dredger	134
Cutter suction dredger ABU AL ABYADH for NMDC	145
Sensitive environmental cutter dredger for Samsung	146
Mighty MASHHOUR for Suez Canal	147
Dismountabe IHC Beaver dredgers	153
CD Al Mirfa	154
CD Kattouf	157