

# 1. Introduction to Dredging Equipment

1.	Introduction to Dredging Equipment .....	1
1.1.	Introduction.....	1
1.2.	Types of dredging equipment .....	2
1.3.	Mechanical dredgers .....	3
1.3.1.	The bucket ladder dredge.....	3
1.3.1.1.	General.....	3
1.3.1.2.	Working method .....	5
1.3.1.3.	Area of application.....	6
1.3.2.	Grab or Clamshell dredger.....	7
1.3.2.1.	General.....	7
1.3.2.2.	Working method .....	7
1.3.2.3.	Area of application.....	9
1.3.3.	Hydraulic cranes (Backhoe and front shovel).....	10
1.3.3.1.	Working method .....	11
1.3.3.2.	Area of application.....	12
1.4.	Hydraulic dredgers.....	13
1.4.1.	Plain suction dredger.....	13
1.4.1.1.	General.....	13
1.4.1.2.	Working method .....	15
1.4.1.3.	Area of application.....	16
1.4.2.	Barge unloading dredger.....	17
1.4.2.1.	General.....	17
1.4.3.	The cutter suction dredger .....	18
1.4.3.1.	General.....	18
1.4.3.2.	Working Method.....	19
1.4.3.3.	Applied working area.....	21
1.4.4.	The bucket wheel dredger.....	22
1.4.5.	Trailing Suction Hopper Dredger .....	23
1.4.5.1.	General.....	23
1.4.5.2.	Working method .....	24
1.4.5.3.	Applied working area.....	26
1.5.	Conclusion .....	27

## 1.1. Introduction

*Definition: A dredgers is a piece of equipment which can dig, transport and dump a certain amount of under water laying soil in a certain time.*

The quantity of soil moved per unit of time is called *Production*.

Dredgers can dig hydraulically or mechanically. Hydraulic digging make use of the erosive working of a water flow. For instance, a water flow generated by a dredge pump is lead via suction mouth over a sand bed. The flow will erode the sand bed and forms a sand-water mixture before it enters the suction pipe. Hydraulic digging is

mostly done with special water jets. Hydraulic digging is mostly done in cohesionless soils such as silt, sand and gravel.

Mechanical digging by knives, teeth or cutting edges of dredging equipment is apply to cohesive soils.

The transport of the dredged soil can be done hydraulically or mechanically too, ether continuously or discontinuously.

	<b>Hydraulically</b>	<b>Mechanically</b>
Continuously	Transport via pipeline	Transport via conveyor belts
Discontinuously		Transport via grab, ship, car

Deposition of soil can be done in simple ways fi by opening the grab, turning the bucket or opening the bottom doors in a ship. Hydraulic deposition happens when the mixture is flowing over the reclamation area. The sand will settle while the water flows back to sea or river.

Dredging equipment can have these three functions integrated or separated.

The choice of the dredger for executing a dredging operation depends not only on the above mentioned functions but also from other conditions such as the accessibility to the site, weather and wave conditions, anchoring conditions, required accuracy and so on.

## 1.2. Types of dredging equipment

Dredging equipment can be divided in Mechanical Dredgers and Hydraulic Dredgers. The differences between these two types are the way that the soil is excavated; either mechanical or hydraulic.

Mechanical dredgers are

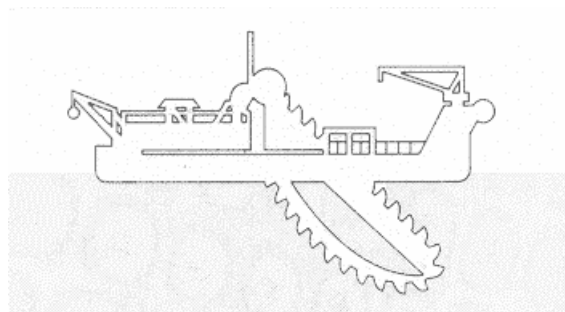

Bucket ladder dredge

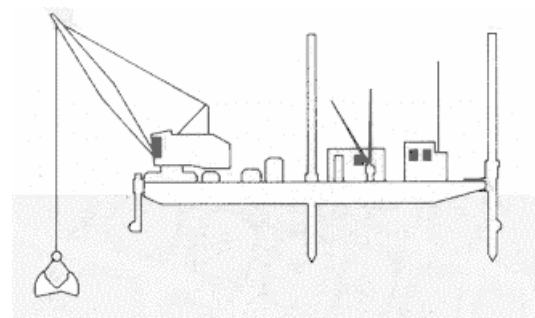

Grab dredge

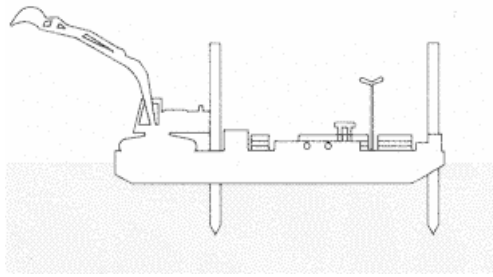

Dipper and backhoe dredge

Hydraulic dredgers are:

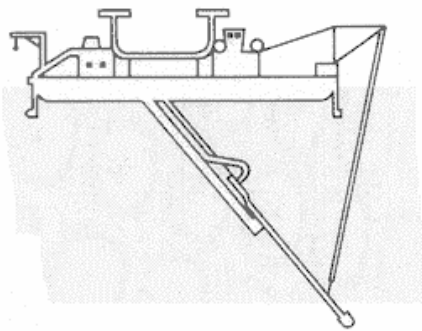

Plain suction dredge

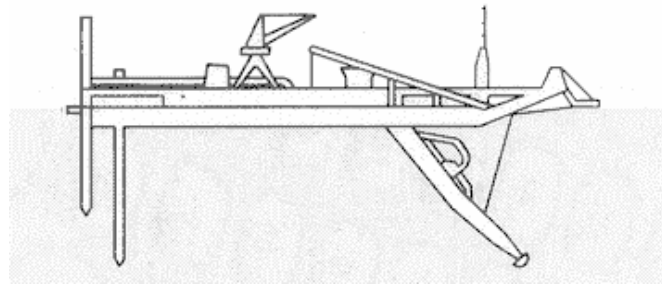

Cutter dredge

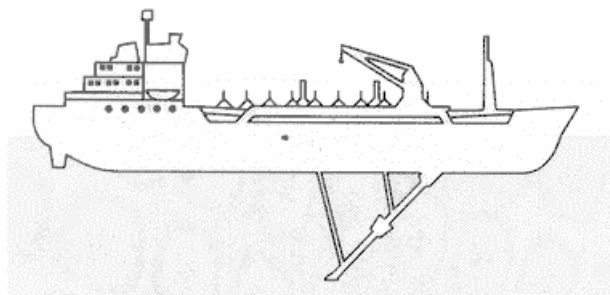

Trailing suction hopper dredge

All dredgers except the trailing suction hopper dredgers are stationary dredgers, which means that they are anchored by wires or (spud)poles.

### **1.3. Mechanical dredgers**

#### **1.3.1. The bucket ladder dredge**

##### **1.3.1.1. General**



*The bucket ladder dredge "Big Dalton"*

The bucket ladder dredge or bucket chain dredger is a stationary dredger, which has an endless chain of buckets carried by the so-called ladder, positioned in the well of a U-shape pontoon. The chain is driven by the upper tumbler, a pentagonal, at the upper part of the ladder and fixed at the bottom with lower tumbler, mostly a heptagonal. Under the ladder the chain hangs freely, while on the upper side of the ladder the chain is supported and guided by rollers. The buckets filled during their rotation over the lower tumbler are emptied by the rotation over upper tumbler. The soil from there is guided via shutters to an alongside layer barge. Bucket sizes vary from 30 liters to 1200 liters. Rock bucket dredgers do have a double set of buckets; a small rock bucket and a bigger soft soil bucket.

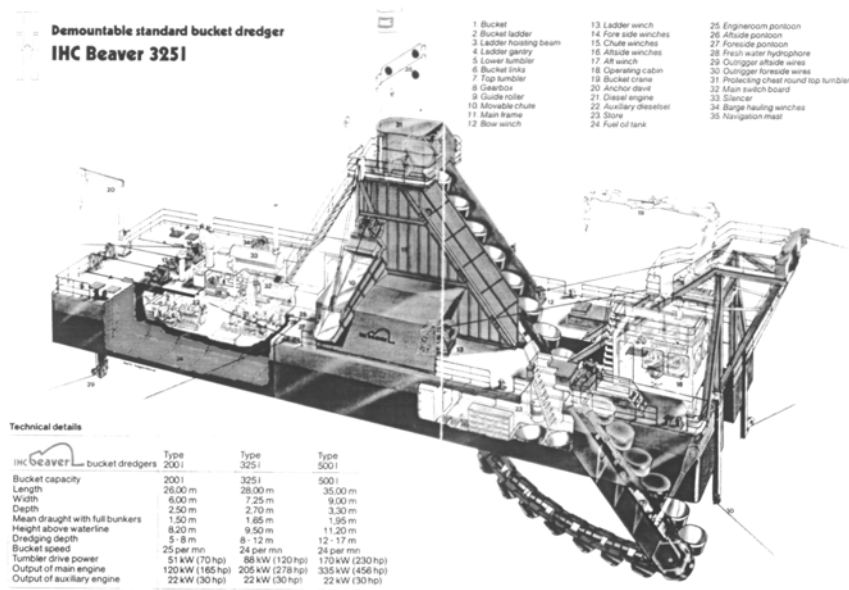

### 1.3.1.2. Working method

The bucket ladder dredge is positioned on 6 wires. Under working conditions the dredge swings around her bow anchor. The bow anchor line or headline can have length longer than 1000 m. In order to avoid dragging of the wire over the soil, which results in a smaller radius, the wire is supported by a headline pontoon. As a result of this long headline the cut width can be large as well (200 m or more). The sideline winches take care of the swinging of the dredge as well as the power necessary for the cutting process. The swing speed depends on the spoil condition, the layer thickness cut and forward step (pawl length)

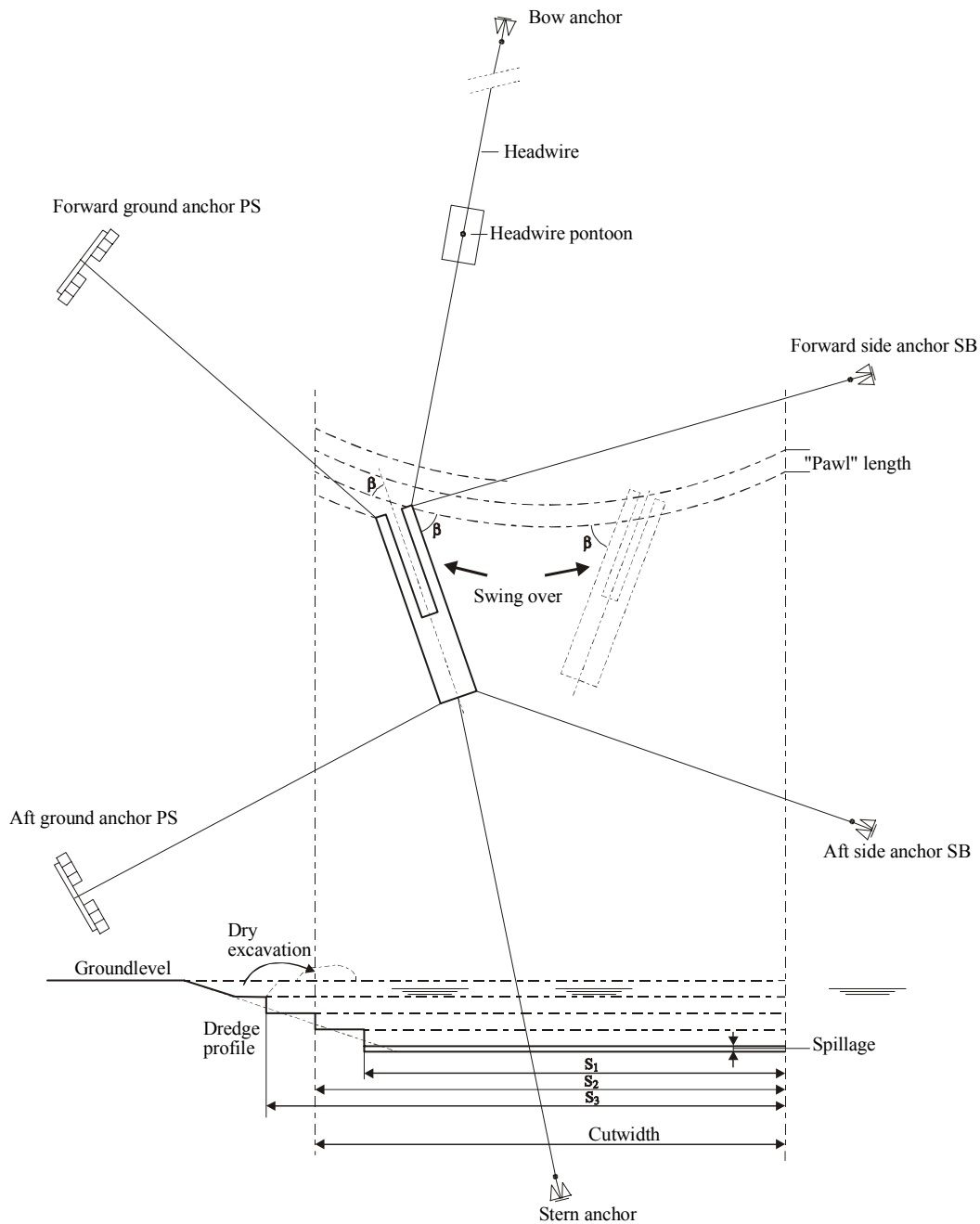

### 1.3.1.3. Area of application

A bucket dredgers can be applied in almost all soils, from soft silt and clays to soft rock depending on the power on and the strength of the bucket chain. They are use in blasted rock as well.

The maximum dredging depth depends on the size of the dredger. Bucket ladder dredgers with a maximum dredging depth of over the 30 m are built.

However for such dredgers the minimum dredging depth is almost 8 m.

Nowadays they are often used for dredging contaminated mud, because they can dig the soil under in situ density conditions.

The bucket ladder dredge can not be applied under offshore conditions and is certainly an obstruction for shipping. Compared to hydraulic dredgers the production is rather low.

### 1.3.2. Grab or Clamshell dredger



#### 1.3.2.1. General

The grab dredger is the most common used dredger in the world, especially in North America and the Far East.

It is a rather simple and easy to understand stationary dredger with and without propulsion. In the latter the ship has a hold (hopper) in which it can store the dredge material, otherwise the material is transported by barges. The dredgers can be moored by anchors or by poles (spuds)

The capacity of a grab dredger is expressed in the volume of the grab. Grab sizes varies between less than 1 m<sup>3</sup> up to 200 m<sup>3</sup>.

The opening of the grab is controlled by the closing and hoisting wire or by hydraulic cylinders.

#### 1.3.2.2. Working method

For grab dredgers the method of anchoring and the positioning system plays an important role for the effectiveness of the dredger.

At every pontoon position an area as wide as possible will be dredged. Looking from the centerline the volume to be dredged at the position decreases with the angle to the centerline.

The positioning is important to localize the bit of the grab. This helps the dredge master to place the next bit after the fore going.

Releasing the aft wires and pulling the fore wires does the movement of the pontoon. When the dredgers have spud poles, this movement is done by a spud operation, which is more accurate than executed by wires.

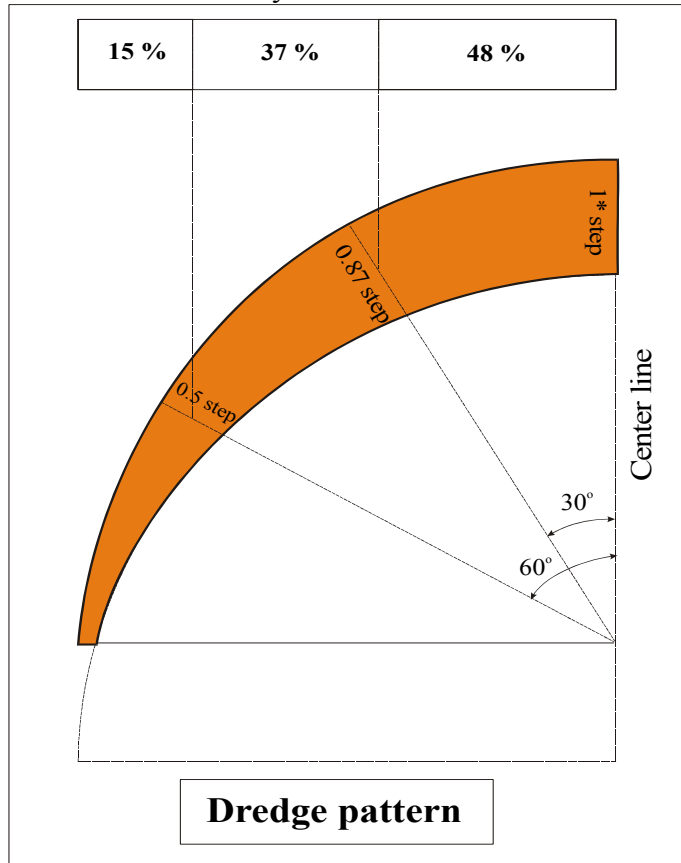

The dredging process is discontinuously and cyclic.

1. Lowering of the grab to the bottom
2. Closing of the grab by pulling the hoisting wire
3. Hoisting starts when the bucket is complete closed
4. Swinging to the barge or hopper
5. Lowering the filled bucket into the barge or hopper
6. Opening the bucket by releasing the closing wire.

The principle of this hoisting operation is given in the figure below. In order to avoid spinning of the clamshell a so-called taught wire is connected to the clamshell.



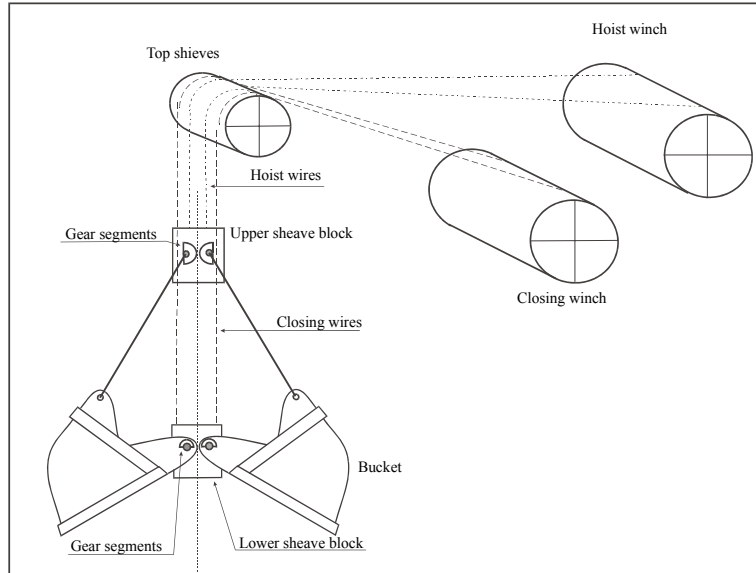

### 1.3.2.3. Area of application

The large grab dredgers are used for bulk dredging. While the smaller ones are mostly used for special jobs, such as:

- Difficult accessible places in harbors
- Small quantities with strongly varying depth.
- Along quay walls where the soil is spoiled by wires and debris
- Borrowing sand and gravel in deep pits
- Etc.

The production of a grab depends strongly on the soil. Suitable materials are soft clay, sand and gravel. Though, boulder clay is dredged as well by this type of dredger. In soft soils light big grabs are used while in more cohesive soils heavy small grabs are favorable.

The dredging depth depends only on the length of the wire on the winches. However the accuracy decreases with depth.

### 1.3.3. Hydraulic cranes (Backhoe and front shovel)



Hydraulic cranes are available in two models the backhoe and the front shovel. The first is used most. The difference between those two is the working method. The backhoe pulls the bucket to the dredger, while the front shovel pushes. The last method is only used when the water depth is insufficient for the pontoon. These stationary dredgers are anchored by three spud poles; two fixed to the front side of the pontoon and one movable at the aft side. This means that the dredging depth is limited to about 15 m. (maximum 25 m). At the front of the pontoon is normally a standard crane mounted. Here pontoon deck is lower to increase the dredging depth. Bucket sizes vary from a few m<sup>3</sup> to 20 m<sup>3</sup>.

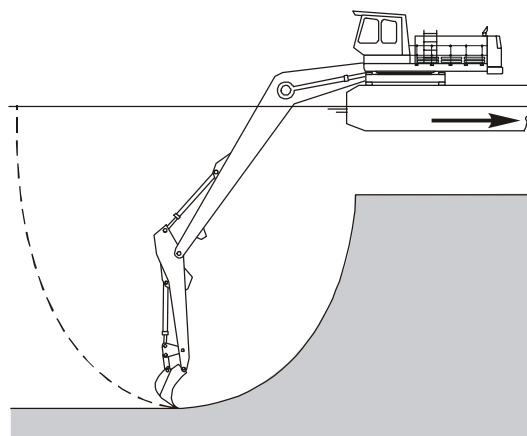

Backhoe dredge

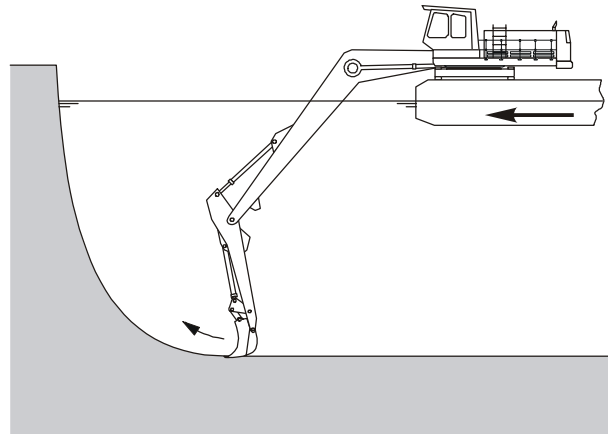

Front shovel

### 1.3.3.1. Working method

During dredging the pontoon is lifted a few out of the water by wires running over the spud poles. A part of the weight of the dredger is now transferred via the spuds to the bottom, resulting a sufficient anchoring to deliver the required reaction for the digging forces. Besides that the dredger is in this case less sensible for waves. The bucket is placed and filled by hydraulic cylinders on the boom and the bucket arm.

Due to the small radius of the boom and arm is the cut width limited to 10 to 20 m, see figure below.

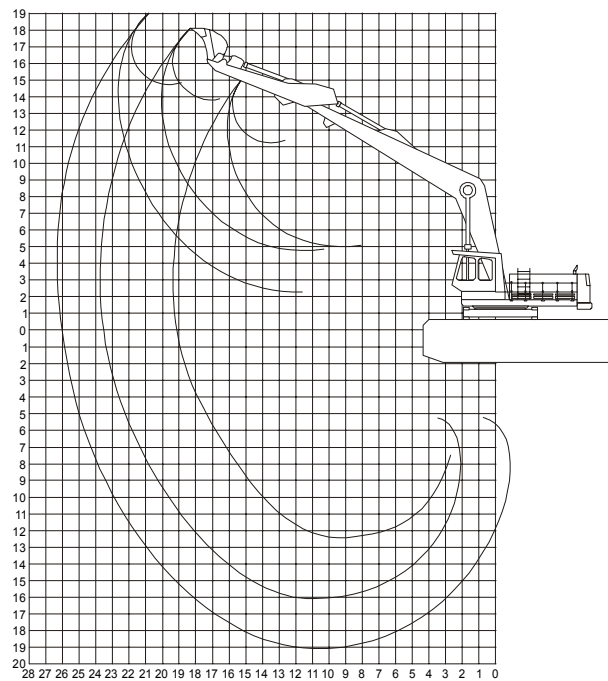

The effective dredging area depends on the swing angle and the forward step per pontoon position. A small step results in a large width and a large step in a small width, however the total area is almost the same.

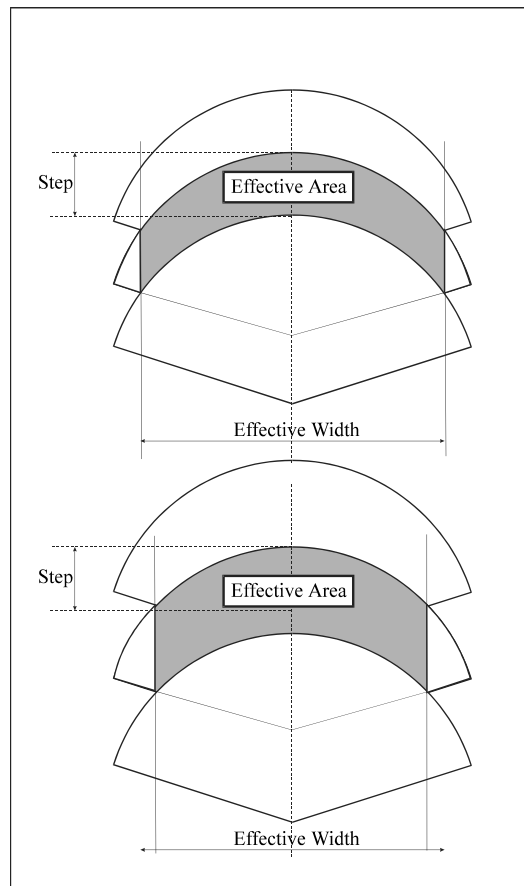

### 1.3.3.2. Area of application

This is roughly the same as for the clamshell dredgers with the exception dredging depth over the 25 m

## 1.4. Hydraulic dredgers

### 1.4.1. Plain suction dredger

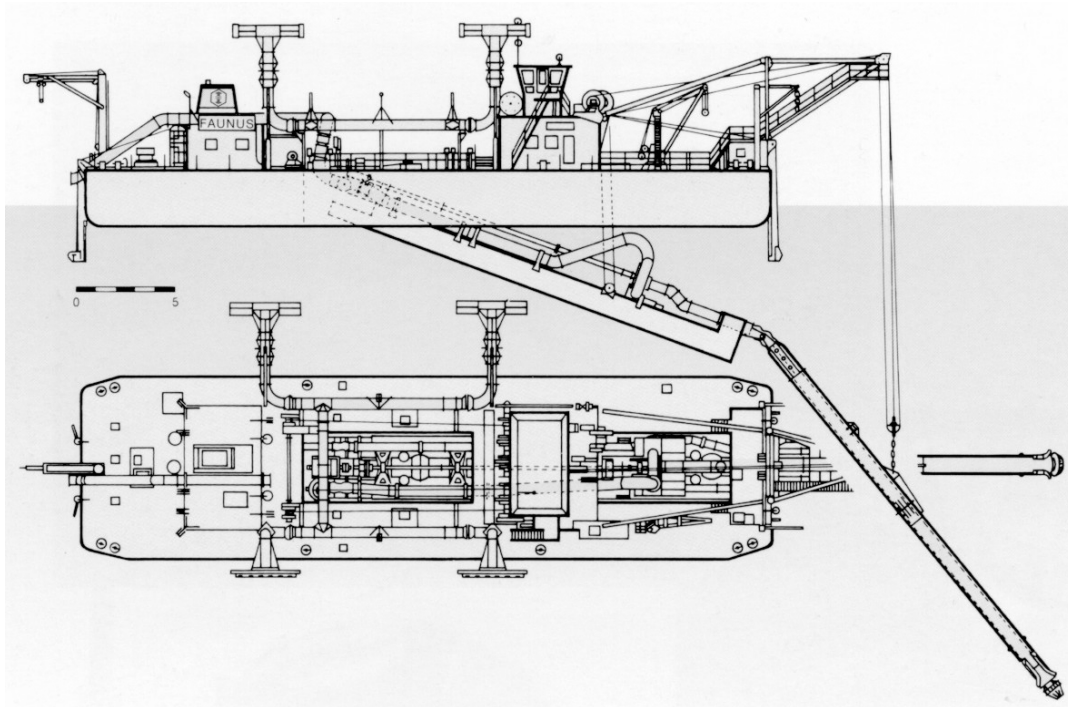

#### 1.4.1.1. General

A plain suction dredger is a stationary dredger that position on one ore more wires, with at least one dredge pump, which is connected to the suction pipe and the delivery pipe. The suction pipe is situated in a well in front of the pontoon.

Good production can only achieved by this kind of dredgers either the soil is free running sand or the cut or breach height is sufficient (at least 10 m)

The discharge of the soil sucked is done either by pipeline or by barges.

Most suction dredgers are equipped with jet water pump(s) to assist either the beaching process or to improve the mixture forming process near the suction mouth.

#### Types of plain suction dredgers

There are different types to be distinguished.

#### 1. Barge Loading suction dredger

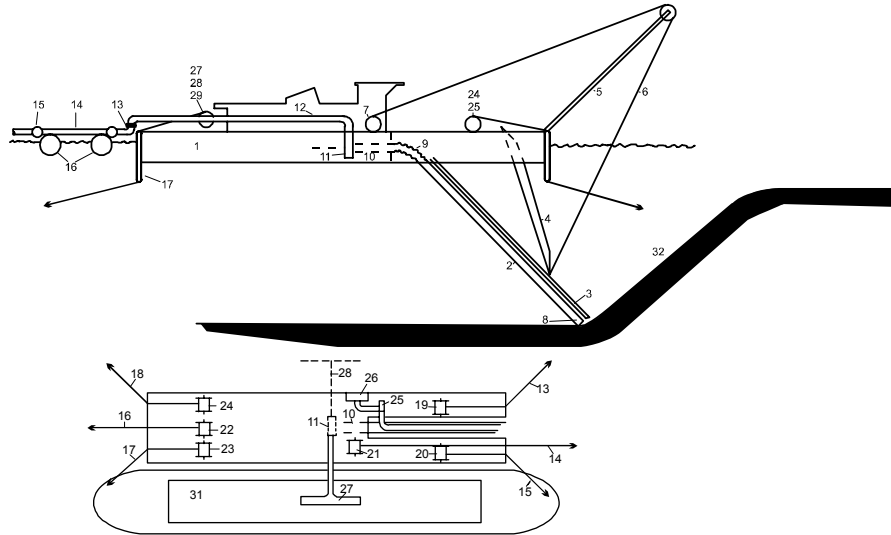

Used when the transport distances are too large for direct pumping

**2. Standard plain suction dredger**

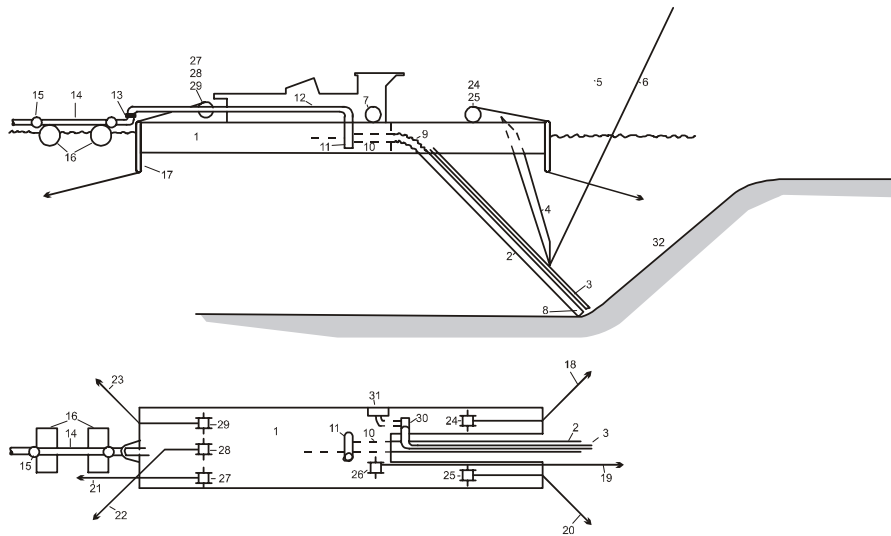

Discharged the material direct via pipeline to the reclamation area.

**3. Deep suction dredger**

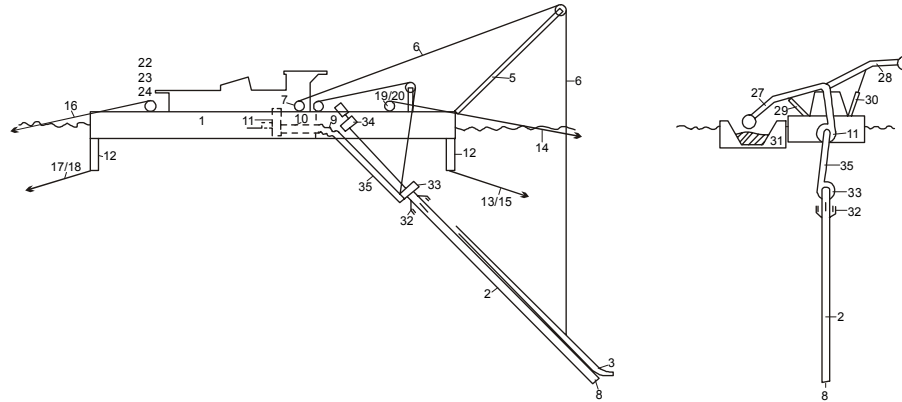

This dredger is equipped with an underwater pump and have two appearances; the standard or from the barge loading type. When dredging depth exceeds the 30 m this dredgers is more appropriate than the standard one.

#### 4. Dustpan dredger

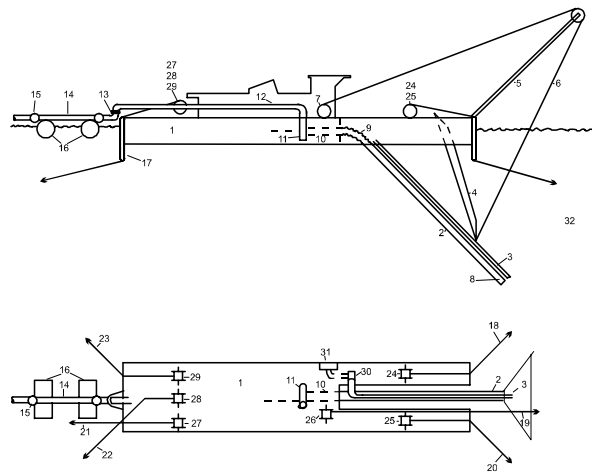

A suction dredger with a wide suction mouth, which makes it possible to dredge with reasonable productions low cut heights.

##### 1.4.1.2. Working method

The working method is based on the “breaching process” and the erosion created by the flow near the suction mouth, generated by the dredge pump.

Breaching is a process of soil shearing on a slope caused by local instabilities or by erosion of the density current running along the slope to the suction mouth

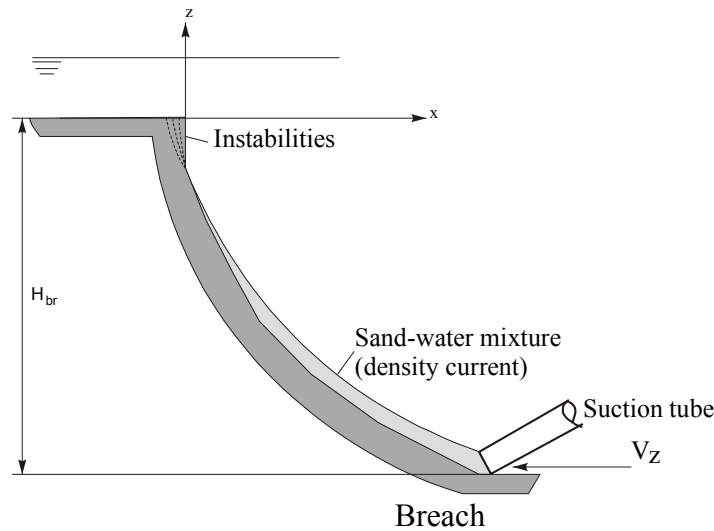

This process is essential for this type of dredger and is fully determined by the soil conditions of the slope, from which the permeability and the relative density are the most important parameters. The dredge pattern made by a plain suction dredger is shown below.

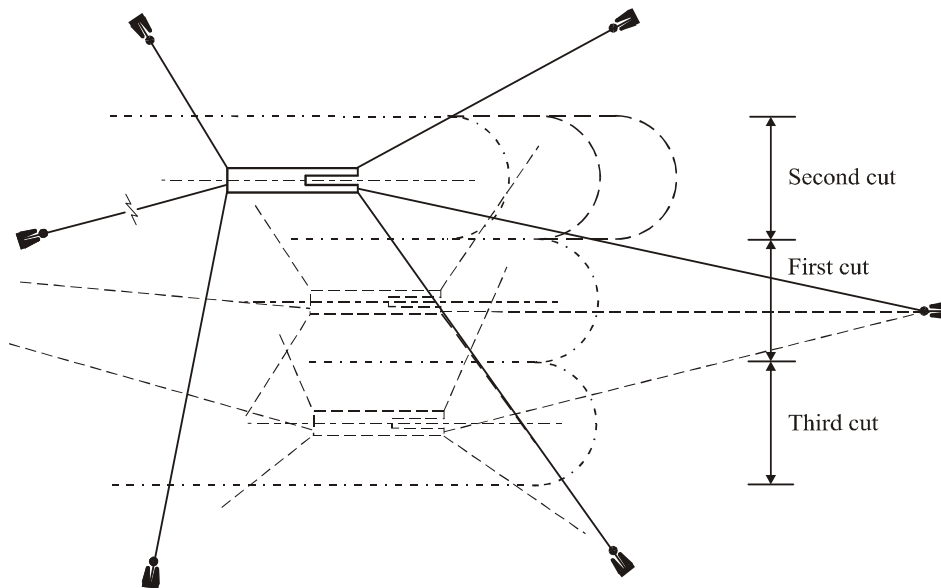

The length of the cut depends, inside the borrow area, on the position of the anchors. Mostly the anchors are laid down in such a way that more cuts can be made without repositioning the anchors. However this depends not only of the length of the anchoring wires but also from the “breachability” of the soil.

#### 1.4.1.3. Area of application

Due to the lack of cutting devices this type of dredger is only suitable in non-cohesive soils. Furthermore this method excludes accurate dredging work. Dredging under



offshore conditions is possible with special equipment. As already said borrowing in deep pits of over 100 m depth is possible.

These types of dredgers are frequently used in borrow pits for reclamation areas as well as for the borrowing of sand for the concrete industry.

### 1.4.2. Barge unloading dredger

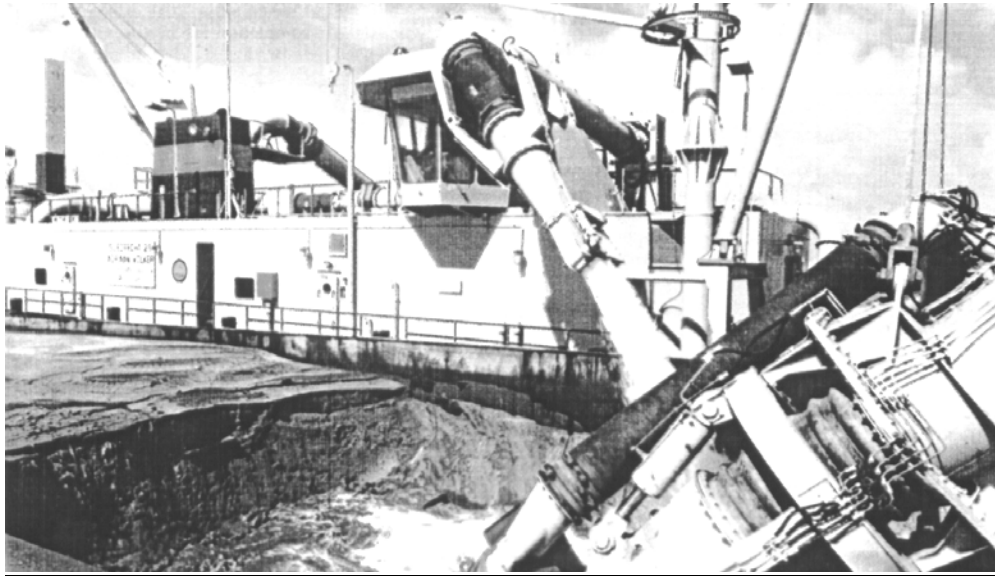

#### 1.4.2.1. General

Barge unloading dredgers are used for emptying loaded barges either by suction dredgers or by bucket ladder dredgers and cranes.

The barge-unloading dredger is a stationary special suction dredger anchored by spuds near the shore, where the water depth is sufficient for the loading barges to come along side the dredger.

The water for the unloading and the transport is supplied into the barge by a jet.

### 1.4.3. The cutter suction dredger



#### 1.4.3.1. General

The cutter suction dredger is a stationary dredger equipped with a cutter device (cutter head) which excavate the soil before it is sucked up by the flow of the dredge pump(s). During operation the dredger moves around a spud pole by pulling and slacking on the two fore sideline wires. This type of dredger is capable to dredge all kind of material and is accurate due to their movement around the spud. The spoil is mostly hydraulically transported via pipeline, but some dredgers do have barge-loading facilities as well.

Sea going cutter suction dredgers have their own propulsion, however this is only used during (de) mobilization.

Cutter power ranges from 50 kW up to 5000 kW, depending on the type of soil to be cut.



Custom build dredger

The more powerful dredgers are capable to dredge rock  
 The small and medium size cutter suction dredgers are deliverable in a demountable application. In that case the hull consists out of five or more pontoons. The central pontoon contains the machinery.



Standard Beaver dredger

#### 1.4.3.2. Working Method

The rotating cutter excavates the soil during their movement, generated by the side winches, from port side to starboard and vice versa.

The necessary side winch force depends not only on the type of soil but also on:

- The rotation direction of the cutter head; (over cutting) rotation in the direction of the swing movement or (under cutting) opposite to that.

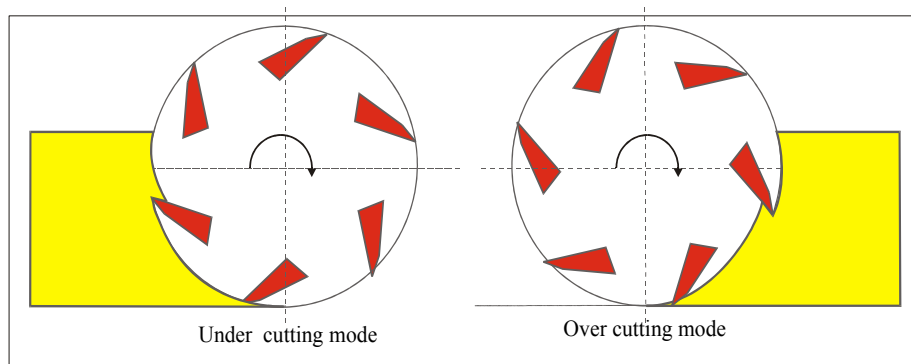

In the over cutting mode the cutter head tries to drag the cutter dredger in the direction of the pulling winch. Braking with the opposite winch may be necessary.

- The position of the anchors in relation to the path of the cutter head. The more the anchor lies in the direction of the moving cutter head the less the required side winch force will be.
- External forces, such as wind, current and waves.

The thickness of the layer, which can be cut in one swing, depends besides on the soil conditions also on the size of the cutter head. At the end of the swing will either the ladder be lowered and the dredger is swung in the opposite direction or the dredger will make a “step” forwards.

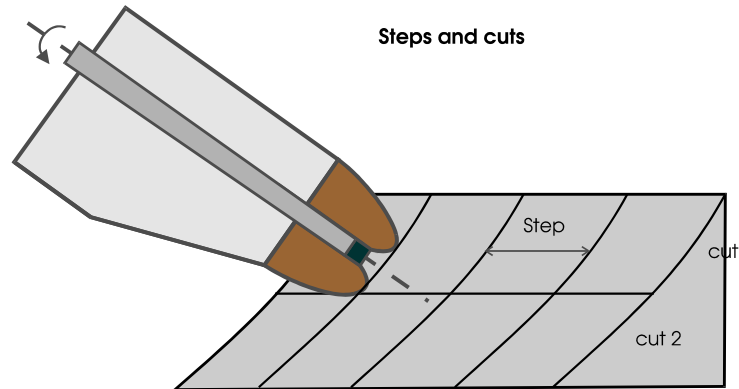

As said earlier the dredgers swings around a pole the working spud, which is positioned mostly in a carriage. The spud carriage can be moved over a distance of 4 to 6 m. by a hydraulic cylinder. When the working spud is set on the ground the dredger is pushed forward when the cylinder pushes against the carriage. This forward movement is called step and depends also on the soil conditions and the size of the cutter head.

During a step the breach is cut in one or more cuts.

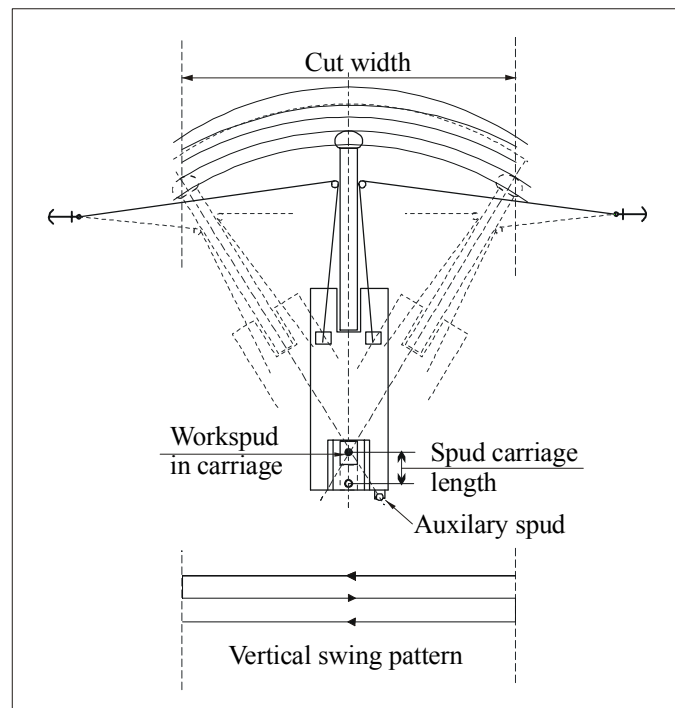

Because the spud stays on the same spot the dredger makes concentric circles during swinging.

Is the stroke of the hydraulic cylinder is maximum the dredger is moved to the centerline of the cut where a second spud at the aft side of the pontoon, the step spud, is lowered. Where after the working spud is hoisted and the carriage is pulled back, the working spud lowered to the ground and the step spud hoisted again. The dredger can make a new cycle again.

#### 1.4.3.3. Applied working area

Cutter suction dredgers are applied for dredging harbors, channels, reclamation areas and so on. The transport distance of the mixture is limited to maximum 10 km. She is very useful when the accuracy of the works is important. As said already the cutter dredger can dredge all kinds of soil.

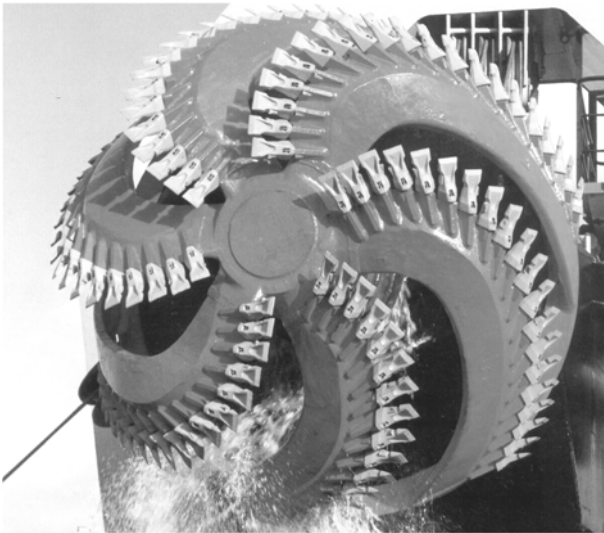

clay cutter



Rock Cutter

For dredging under offshore conditions is this dredger less suitable.

#### 1.4.4. The bucket wheel dredger



This dredger is, with the exception of the cutter head, is comparable with the cutter suction dredger. The rotation axis of the bucket wheel is perpendicular with the ship axis. The wheel contains 10 – 14 open or closed buckets.

Due to the construction of the drive the wheel is difficult to replace and therefore less universal than the cutter suction dredger.

Its application area is the same as the cutter dredger with the exception of hard rock. This dredger is often used in areas with constant conditions, such as the sea mining.

### 1.4.5. Trailing Suction Hopper Dredger



#### 1.4.5.1. General

A Trailing Suction Hopper Dredger (TSHD) is a self-propelled sea-going or inland vessel equipped with a hold, called hopper, and a dredging installation by which it can fill and/or empty the hopper.

The basic options of a THSD are:

- One or more suction tubes provided with suction mouths (dragheads) which are dragged over the seabed during dredging.
- One or more dredge pumps to suck the material from the seabed.
- A hopper in which the dredged material can settle.
- Easy operational bottom doors or valves in the hopper to dump the dredge material
- Gantries and winches to operate the suction tubes.
- A swell compensator to control the contact between the suction mouth and the seabed when dredging in waves.

The size of a TSHD is expressed in the hopper volume and varies between a few hundred m<sup>3</sup> up to 33000 m<sup>3</sup>



A 23350 and 700 m<sup>3</sup> hopper dredger

#### 1.4.5.2. Working method

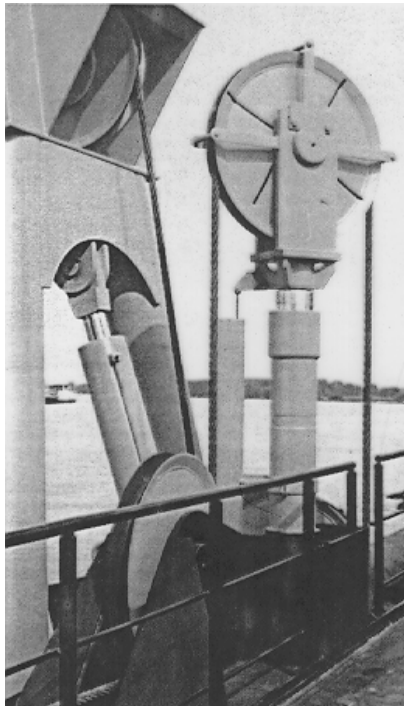

When arrived at the dredging area, the speed of the vessel is reduced to about 2 to 3 knots (1 to 1.5 m/s), where after the suction tubes are lowered till the seabed and the dredge pumps started. When the suction tubes reach the seabed the swell compensator reacts, easy to see by the movement of the hydraulic cylinder.

Nowadays electronic charts and screens shows where and how much there is to dredge.

During dredging a mixture of soil and water is dumped into the hopper. When dredging non-settling slurries dredging is stopped when the mixture reach the overflow; a device to discharge fluids from the hopper above a certain level.

When dredging settling slurries dredging is continue after the mixture has reached the top of the overflow. Now the majority of the soil will settle in the hopper, while the fine particles together with the water will leave the hopper via the overflow.



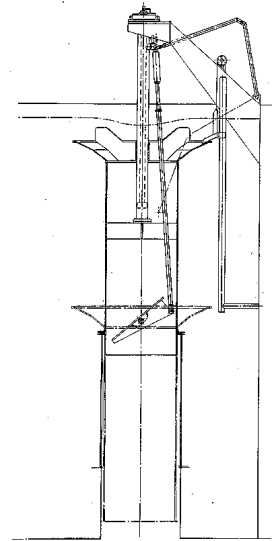
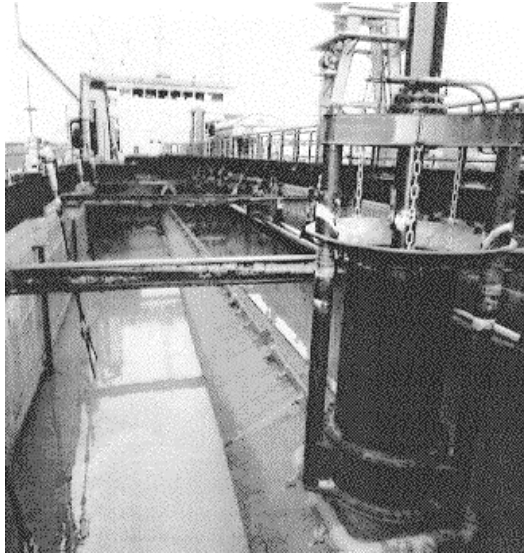

### Overflows

After the overflow is reached, the dredging procedure depends either the overflow level is fixed or variable.

- With a fixed overflow level the loading is continued till the ship has reached the allowed draught. The mixture volume in the hopper stays constant during this part of the loading process. Depending on the bulk density of the settled material there will be a certain volume of water above the settled material. (constant volume system)
- Is de THSD provided with a variable overflow system, the overflow may be lowered when the ship has reached the allowed draught, on order to replace the water volume by settled material. (constant tonnage system)

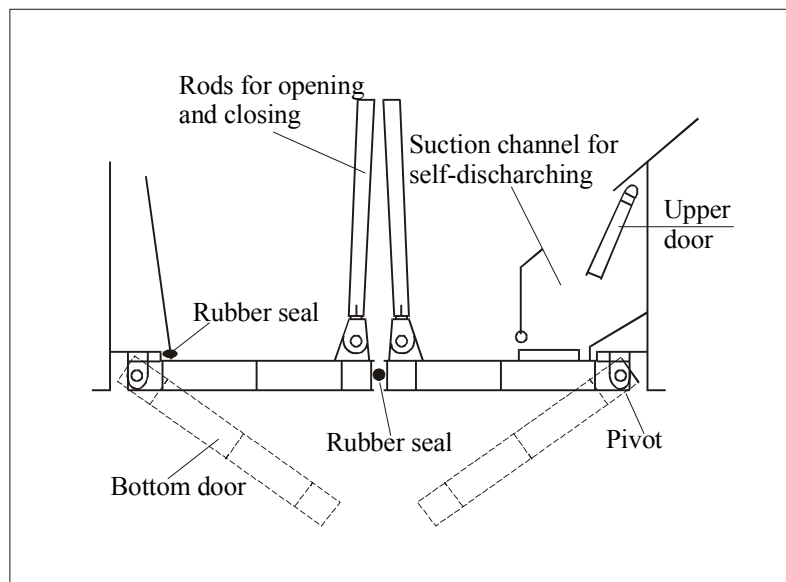

Bottom door

When the hopper is filled, dredging is stopped and the suction tubes placed on the deck of the ship, where after she is ready to sail to the unloading area. The THSD can be unloaded either by opening the bottom doors or to pump the load via a pump ashore equipment to the reclamation area.



Pumping ashore (rain bowing)

#### **1.4.5.3. Applied working area**

The THSD is a free sailing vessel and does not hinder other shipping during dredging and is therefore ideal for dredging in harbors and shipping channels inshore as well as offshore. The seagoing vessels are very suitable for borrowing sand under offshore conditions (wind and waves) and large sailing distances. The dredged material is dredged, transported and discharged by the vessel without any help from other equipment.

(De)mobilization is very easy for this type of dredger. It can sail under its own power to every place in the world.

Suitable materials for the THSD to dredge are soft clays, silt sand and gravel. Firm and stiff clays are also possible but can give either blocking problem in the draghead and/or track forming in the clay. In that case the draghead slips into foregoing tracks, resulting in a very irregular clay surface. Dredging rock with a THSD is in most cases not profitable. It requires very heavy dragheads with rippers and the productions are rather low.



Modern 9000 m<sup>3</sup> Hopper dredger with one dredge pipe

### 1.5. Conclusion

Summarized it can be stated that every type of dredger has its own applied working area in which its production is optimal in a technical way as well as in an economical way. It will be clear that the boundaries of these applied working areas are not strictly determined, but are also determined by other working conditions, which can differ from job to job.

In the table below the possibilities of the different types are shortly summarized.

	Bucket Dredger	Grab Dredger	Backhoe Dredger	Suction Dredger	Cutter Dredger	Trailer Dredger	Hopper Dredger
Dredging sandy materials	yes	yes	yes	yes	yes	yes	yes
Dredging clayey materials	yes	yes	yes	no	yes	yes	no
Dredging rocky materials	yes	no	yes	no	yes	no	no
anchoring wires	yes	yes	no	yes	yes	no	yes
Maximum dredging depth [m]	30	> 100	20	70	25	100	50
accurated dredging possible	yes	no	yes	no	yes	no	no
working under offshore conditions possible	no	yes	no	yes	no	yes	yes
Transport via pipeline	no	no	no	yes	yes	no	no
Dredging in situ densities possible	yes	yes	yes	no	limited	no	no